

CLUTCH

	Page
TROUBLESHOOTING	CL-2
CHECK AND ADJUSTMENT OF CLUTCH PEDAL	CL-3
BLEEDING OF CLUTCH SYSTEM	CL-3
INSPECTION OF CLUTCH START SYSTEM	CL-4
CLUTCH MASTER CYLINDER	CL-5
CLUTCH RELEASE CYLINDER	CL-8
CLUTCH UNIT	CL-10

TROUBLESHOOTING

Problem	Possible cause	Remedy	Page
Hard to shift or will not shift	Clutch pedal freeplay excessive	Adjust pedal freeplay	CL-3
	Air in clutch lines	Bleed clutch system	CL-3
	Clutch release cylinder faulty	Repair release cylinder	CL-8
	Clutch master cylinder faulty	Repair master cylinder	CL-5
	Clutch disc out of true, runout is excessive or lining broken	Inspect clutch disc	CL-10
	Splines on input shaft or clutch disc dirty or burred	Repair as necessary	CL-10
	Clutch pressure plate faulty	Replace clutch cover	CL-10
Transmission jumps out of gear	Clutch pilot bearing worn	Replace pilot bearing	CL-10
Clutch slips	Clutch pedal freeplay insufficient	Adjust pedal freeplay	CL-3
	Clutch disc lining oily or worn out	Inspect clutch disc	CL-10
	Pressure plate faulty	Replace clutch cover	CL-10
	Release fork binding	Inspect release fork	CL-10
Clutch grabs/chatters	Clutch disc lining oily or worn out	Inspect clutch disc	CL-10
	Pressure plate faulty	Replace clutch cover	CL-10
	Clutch diaphragm spring bent	Align clutch diaphragm	CL-10
	Engine mounts loose	Repair as necessary	
Clutch pedal spongy	Air in clutch lines	Bleed clutch system	CL-3
	Clutch release cylinder faulty	Repair release cylinder	CL-8
	Clutch master cylinder faulty	Repair master cylinder	CL-5
Clutch noisy	Loose part inside housing	Repair as necessary	
	Release bearing worn or dirty	Replace release bearing	CL-10
	Pilot bearing worn	Replace pilot bearing	CL-10

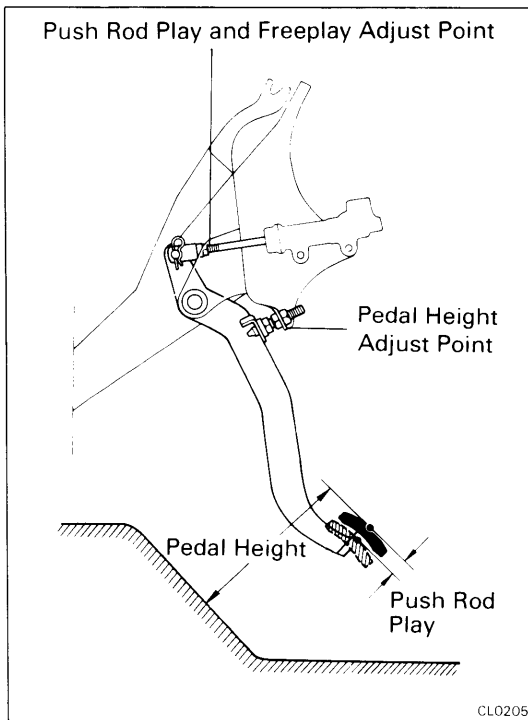

CHECK AND ADJUSTMENT OF CLUTCH PEDAL

1. CHECK THAT PEDAL HEIGHT IS CORRECT

Pedal height from asphalt sheet: 171 — 181 mm
(6.73 — 7.13 in.)

2. IF NECESSARY, ADJUST PEDAL HEIGHT

- Loosen the lock nut and turn the stopper bolt until the height is correct.
- Tighten the lock nut.
- After adjusting the pedal height, check the pedal freeplay.

3. CHECK THAT PEDAL FREEPLAY AND PUSH ROD PLAY ARE CORRECT

Push in on the pedal until the beginning of clutch resistance is felt.

Pedal freeplay: 5 — 15 mm (0.20 — 0.59 in.)
Push rod play at pedal: 1 — 5 mm (0.04 — 0.20 in.)

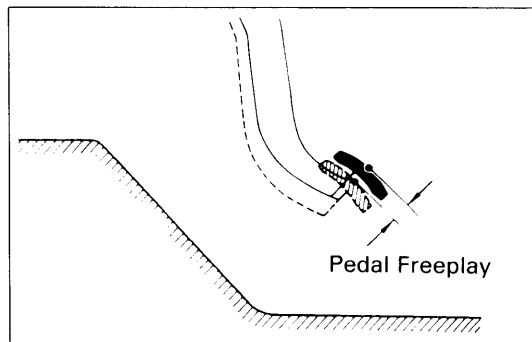

4. IF NECESSARY, ADJUST PEDAL FREEPLAY AND PUSH ROD PLAY

- Loosen the lock nut and turn the push rod until the freeplay and push rod play are correct.
- Tighten the lock nut.
- After adjusting the pedal freeplay, check the pedal height.

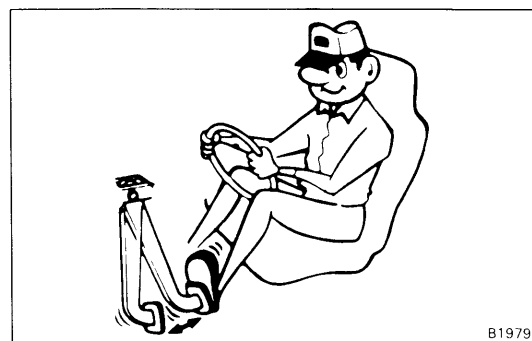

BLEEDING OF CLUTCH SYSTEM

NOTE: If any work is done on the clutch system or if air is suspected in the clutch lines, bleed the system of air.

CAUTION: Do not let brake fluid remain on a painted surface. Wash it off immediately.

1. FILL CLUTCH RESERVOIR WITH BRAKE FLUID

Check the reservoir frequently. Add fluid if necessary.

2. CONNECT VINYL TUBE TO BLEEDER PLUG

Insert the other end of the tube in a half-full container of brake fluid.

3. BLEED CLUTCH LINE

- Slowly pump the clutch pedal several times.
- While depressing the pedal, loosen the bleeder plug until the fluid starts to run out. Then close the bleeder plug.
- Repeat this procedure until there are no bubbles in the fluid.

NOTE: Do not reuse the fluid that was bled. It contains air.

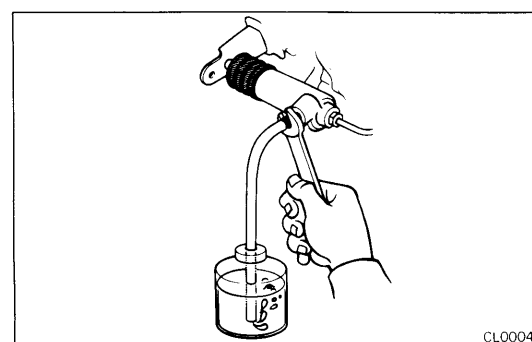

INSPECTION OF CLUTCH START SYSTEM

CHECK CLUTCH PEDAL

1. CHECK THAT PEDAL HEIGHT IS CORRECT
(See page CL-3)
2. CHECK THAT PEDAL FREEPLAY AND PUSH ROD PLAY ARE CORRECT
(See page CL-3)

CHECK CLUTCH START SYSTEM

CHECK CLUTCH START SYSTEM

- (a) Check that the engine does not start when the clutch pedal is released.
- (b) Check that the engine starts when the clutch pedal is fully depressed.
- (c) Check that clearance "A" is greater than 1 mm (0.04 in.) when the clutch pedal is fully depressed.

If necessary, adjust or replace the clutch start switch.

INSPECTION AND ADJUSTMENT OF CLUTCH START SWITCH

1. INSPECT CONTINUITY OF CLUTCH START SWITCH

- (a) Check that there is continuity between terminals when the switch is ON (pushed).
- (b) Check that there is no continuity between terminals when the switch is OFF (free).

If continuity is not as specified, replace the switch.

2. ADJUST CLUTCH START SWITCH

- (a) Measure the pedal stroke, and check the switch clearance "A" using the chart left.
- (b) Loosen and adjust the switch position.

- (c) Recheck that the engine does not start when the clutch pedal is released.

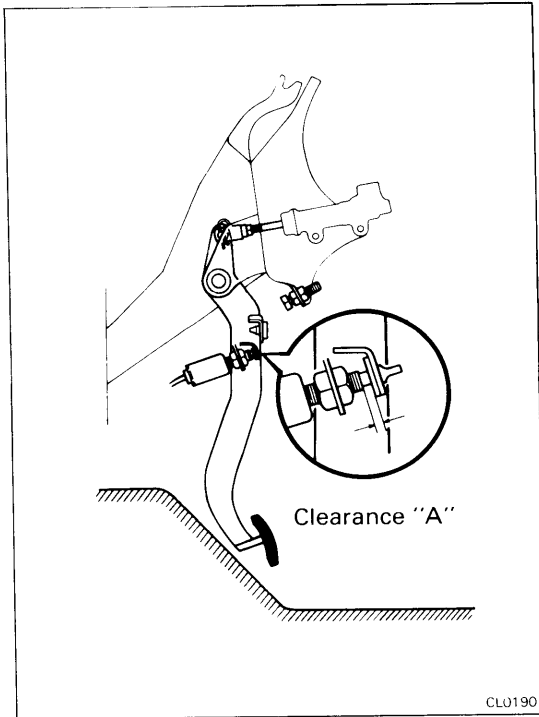

CL0190

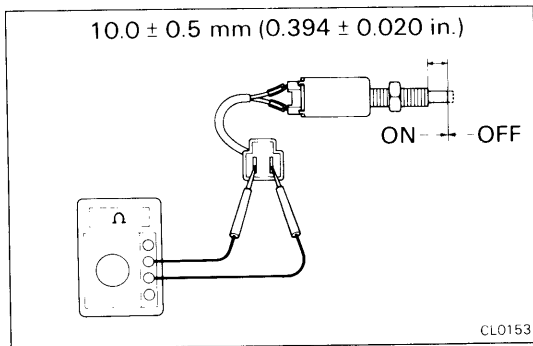

CL0153

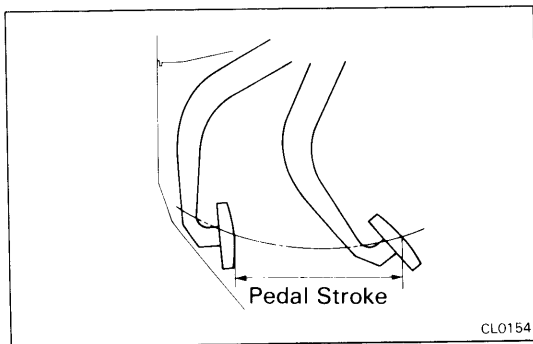

CL0154

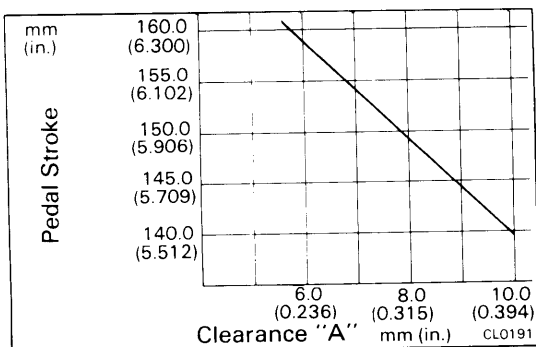

CL0191

CLUTCH MASTER CYLINDER COMPONENTS

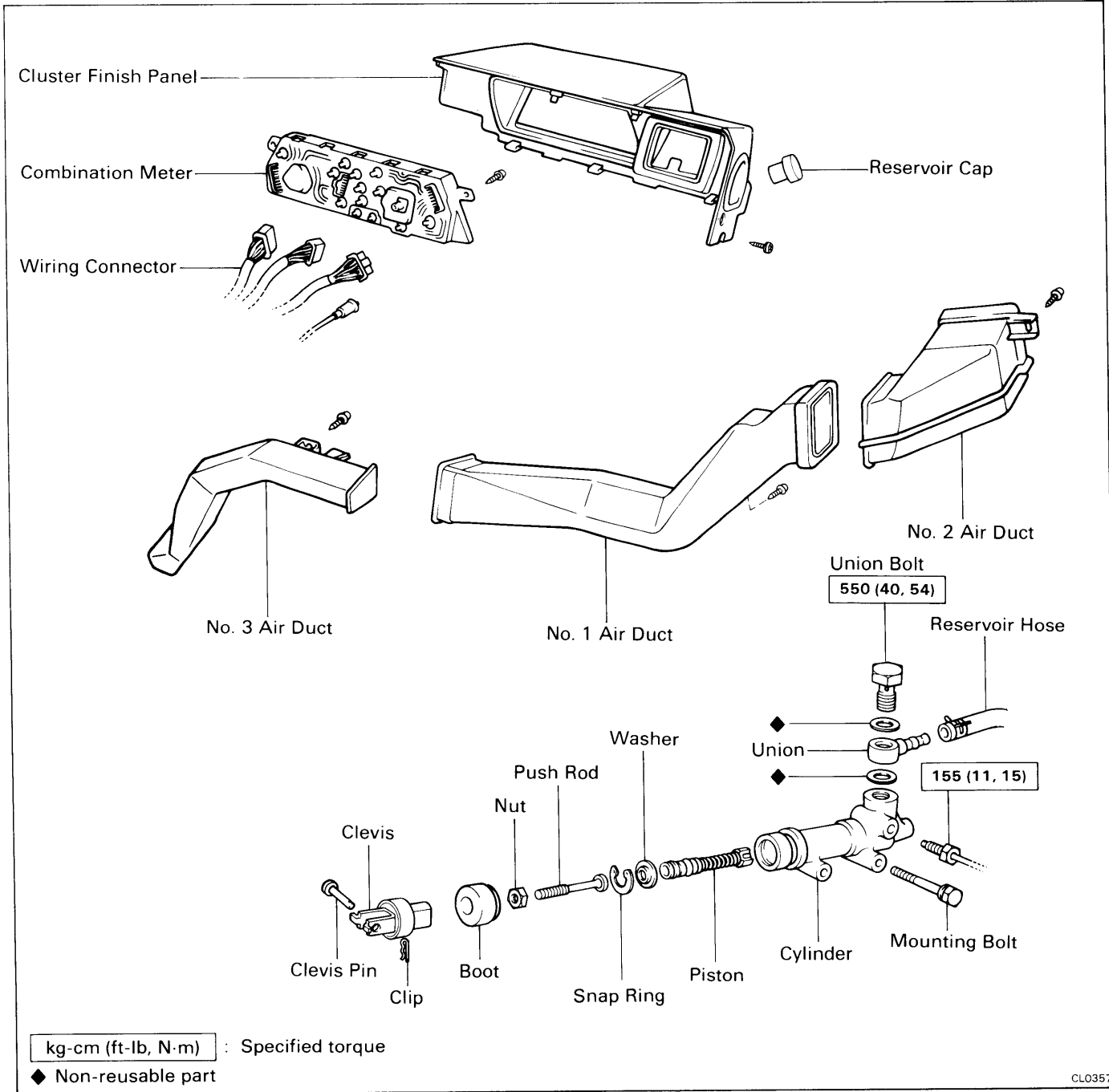

CL0357

REMOVAL OF MASTER CYLINDER

1. DISCONNECT NEGATIVE CABLE FROM BATTERY
2. REMOVE CLUSTER FINISH PANEL
 - (a) Remove the reservoir cap.
 - (b) Remove the five screws and pull the panel toward you.

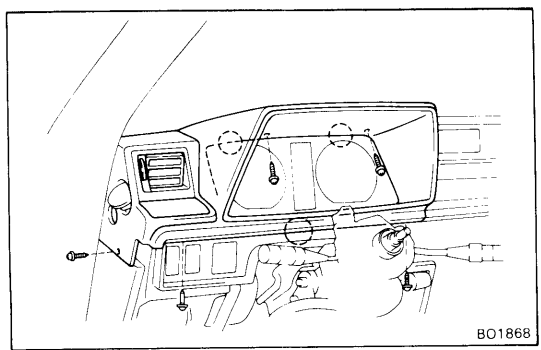

B01868

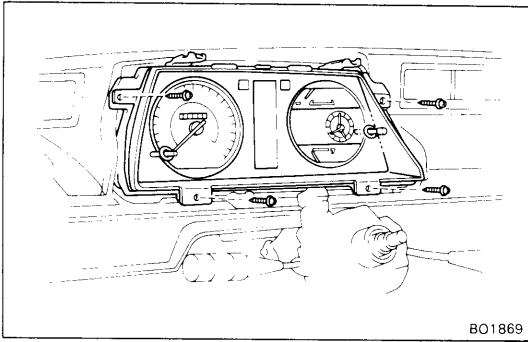

3. REMOVE COMBINATION METER

- (a) Remove the four screws and combination meter.
- (b) Disconnect the speedometer cable and wiring connectors.

4. REMOVE NO. 3 AIR DUCT

5. REMOVE NO. 1 AND NO. 2 AIR DUCTS

6. DISCONNECT RESERVOIR HOSE FROM MASTER CYLINDER, AND PLUG RESERVOIR HOSE

7. REMOVE CLIP AND CLEVIS PIN

8. DISCONNECT CLUTCH LINE UNION

Using SST, disconnect the union.

SST 09751-36011

9. REMOVE MASTER CYLINDER

Remove the mounting bolts and pull out the master cylinder.

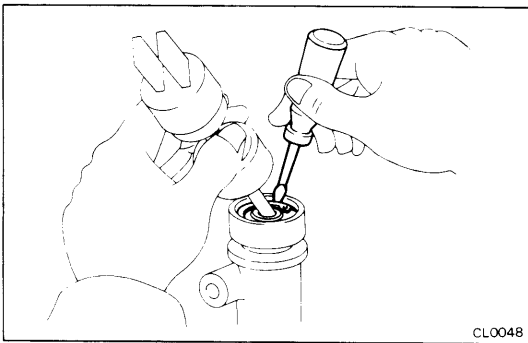

DISASSEMBLY OF MASTER CYLINDER

(See page CL-5)

1. REMOVE PUSH ROD

- (a) Pull back the boot, and using a screwdriver, remove the snap ring.
- (b) Pull out the push rod assembly.

2. REMOVE PISTON

Using compressed air, remove the piston from the cylinder.

3. REMOVE UNION

INSPECTION OF MASTER CYLINDER

NOTE: Clean the disassembled parts with compressed air.

1. INSPECT MASTER CYLINDER BORE FOR SCORING OR CORROSION

If a problem is found, clean or replace the cylinder.

2. INSPECT PISTON AND CUPS FOR WEAR, SCORING, CRACKS OR SWELLING

If either one requires replacement, use the parts from the cylinder kit.

3. INSPECT PUSH ROD FOR WEAR OR DAMAGE

If necessary, replace the push rod.

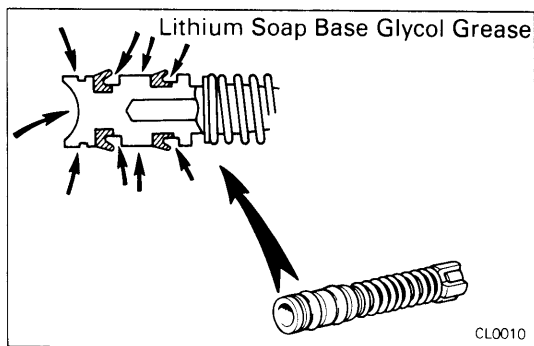

ASSEMBLY OF MASTER CYLINDER

(See page CL-5)

1. COAT PARTS WITH LITHIUM SOAP BASE GLYCOL GREASE, AS SHOWN
2. INSERT PISTON INTO CYLINDER
3. INSTALL PUSH ROD ASSEMBLY WITH SNAP RING
4. INSTALL UNION
 - (a) Install the union as shown and tighten the union bolt by hand.
 - (b) Torque the union bolt.

Torque: 550 kg-cm (40 ft-lb, 54 N·m)

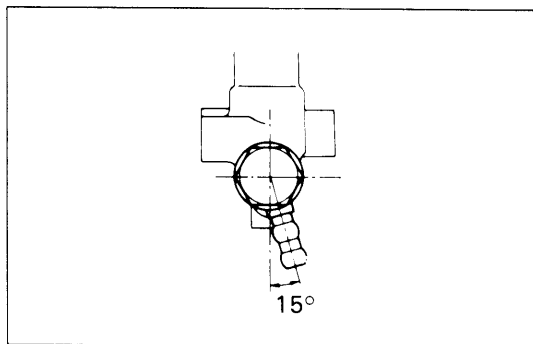

INSTALLATION OF MASTER CYLINDER

(See page CL-5)

1. INSTALL MASTER CYLINDER WITH MOUNTING BOLTS
2. CONNECT RESERVOIR HOSE
3. CONNECT CLUTCH LINE UNION

First finger-tighten the union nut and then tighten it to specified torque with SST.

SST 09751-36011

Torque: 155 kg-cm (11 ft-lb, 15 N·m)
4. INSTALL PUSH ROD ASSEMBLY TO CLUTCH PEDAL

Secure the clevis pin with a clip.
5. INSTALL NO. 1 AND NO. 2 AIR DUCTS
6. INSTALL NO. 3 AIR DUCT
7. INSTALL COMBINATION METER
8. INSTALL CLUSTER FINISH PANEL
9. BLEED CLUTCH SYSTEM

(See page CL-3)
10. CHECK FOR LEAKS
11. CHECK AND ADJUST CLUTCH PEDAL

(See page CL-3)
12. CONNECT NEGATIVE CABLE TO BATTERY

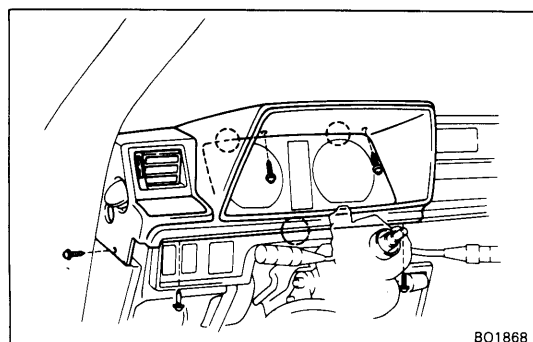
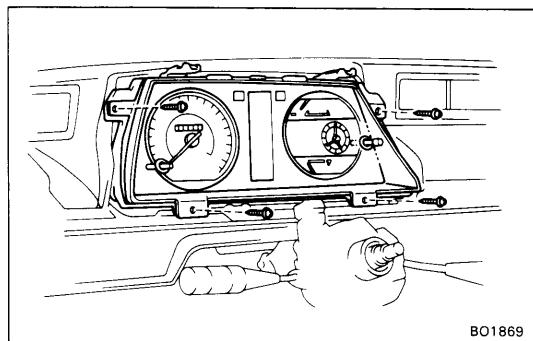

CLUTCH RELEASE CYLINDER COMPONENTS

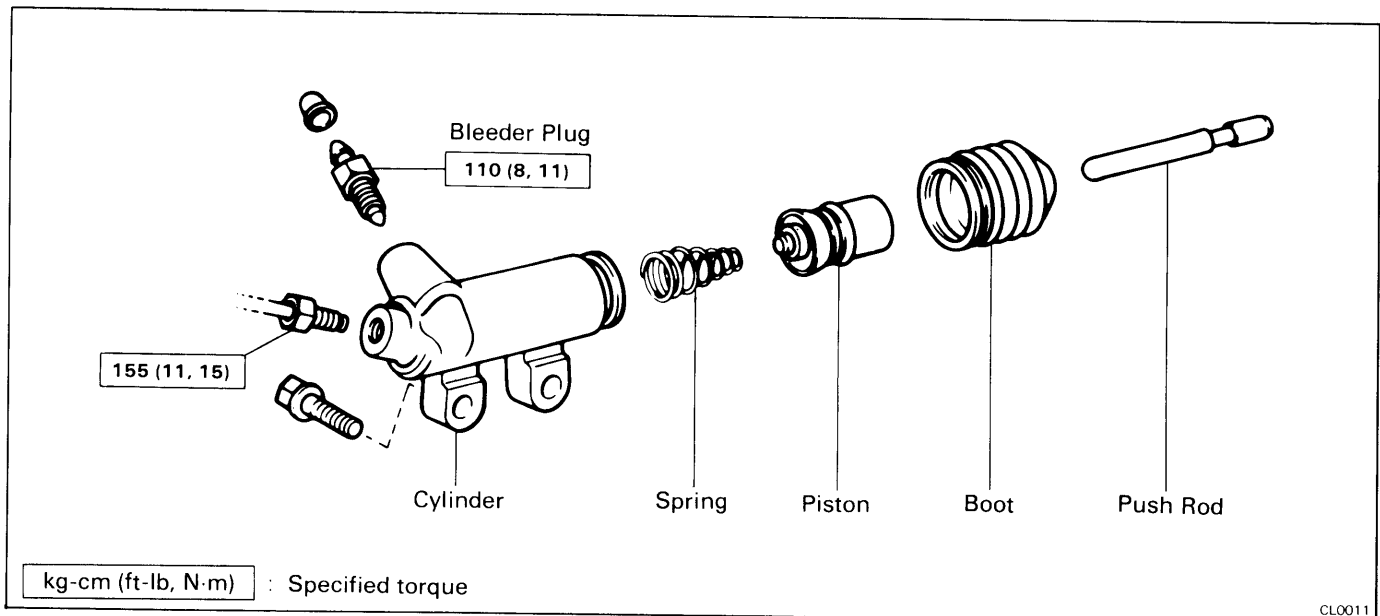

REMOVAL OF RELEASE CYLINDER

- DISCONNECT CLUTCH LINE UNION**
Using SST, disconnect the union.
SST 09751-36011
- REMOVE BOLTS AND PULL OFF RELEASE CYLINDER**

DISASSEMBLY OF RELEASE CYLINDER

- PULL OUT PUSH ROD WITH BOOT**
- REMOVE PISTON AND SPRING**
Using compressed air, remove the piston and spring from the cylinder.

INSPECTION OF RELEASE CYLINDER

NOTE: Clean the disassembled parts with compressed air.

- INSPECT RELEASE CYLINDER BORE FOR SCORING OR CORROSION**
If a problem is found, clean or replace the cylinder.
- INSPECT PISTON AND CUPS FOR WEAR, SCORING, CRACKS OR SWELLING**
If either one requires replacement, use the parts from the cylinder kit.
- INSPECT PUSH ROD FOR WEAR OR DAMAGE**
If necessary, replace the push rod.

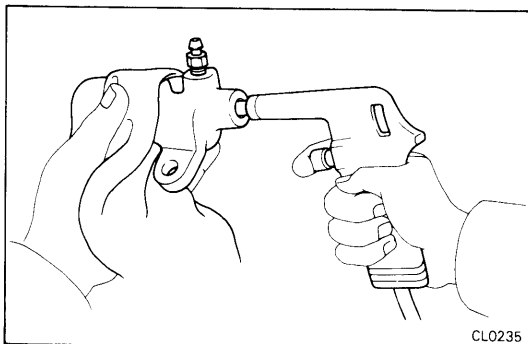

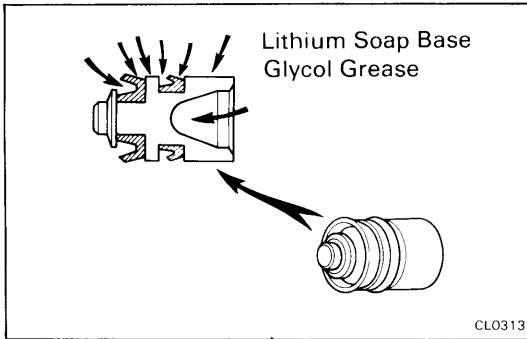

ASSEMBLY OF RELEASE CYLINDER

(See page CL-8)

1. COAT PISTON WITH LITHIUM SOAP BASE GLYCOL GREASE, AS SHOWN
2. INSERT SPRING AND PISTON INTO CYLINDER
3. INSTALL PUSH ROD WITH BOOT

INSTALLATION OF RELEASE CYLINDER

(See page CL-8)

1. INSTALL RELEASE CYLINDER WITH BOLTS
2. CONNECT CLUTCH LINE UNION

First finger-tighten the union nut and then tighten it to specified torque with SST.

SST 09751-36011

Torque: 155 kg-cm (11 ft-lb, 15 N·m)

3. BLEED CLUTCH SYSTEM
(See page CL-3)
4. CHECK FOR LEAKS

CLUTCH UNIT COMPONENTS

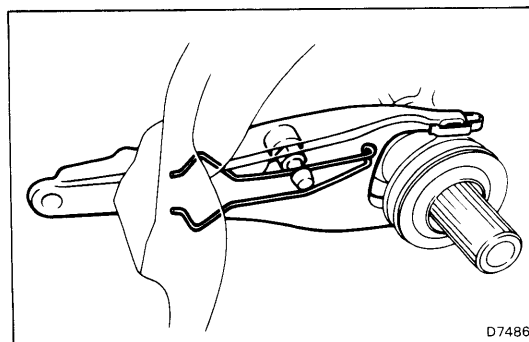
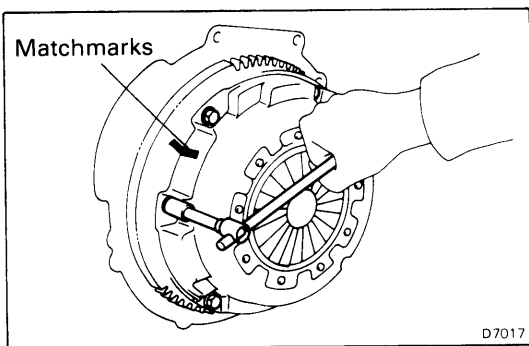
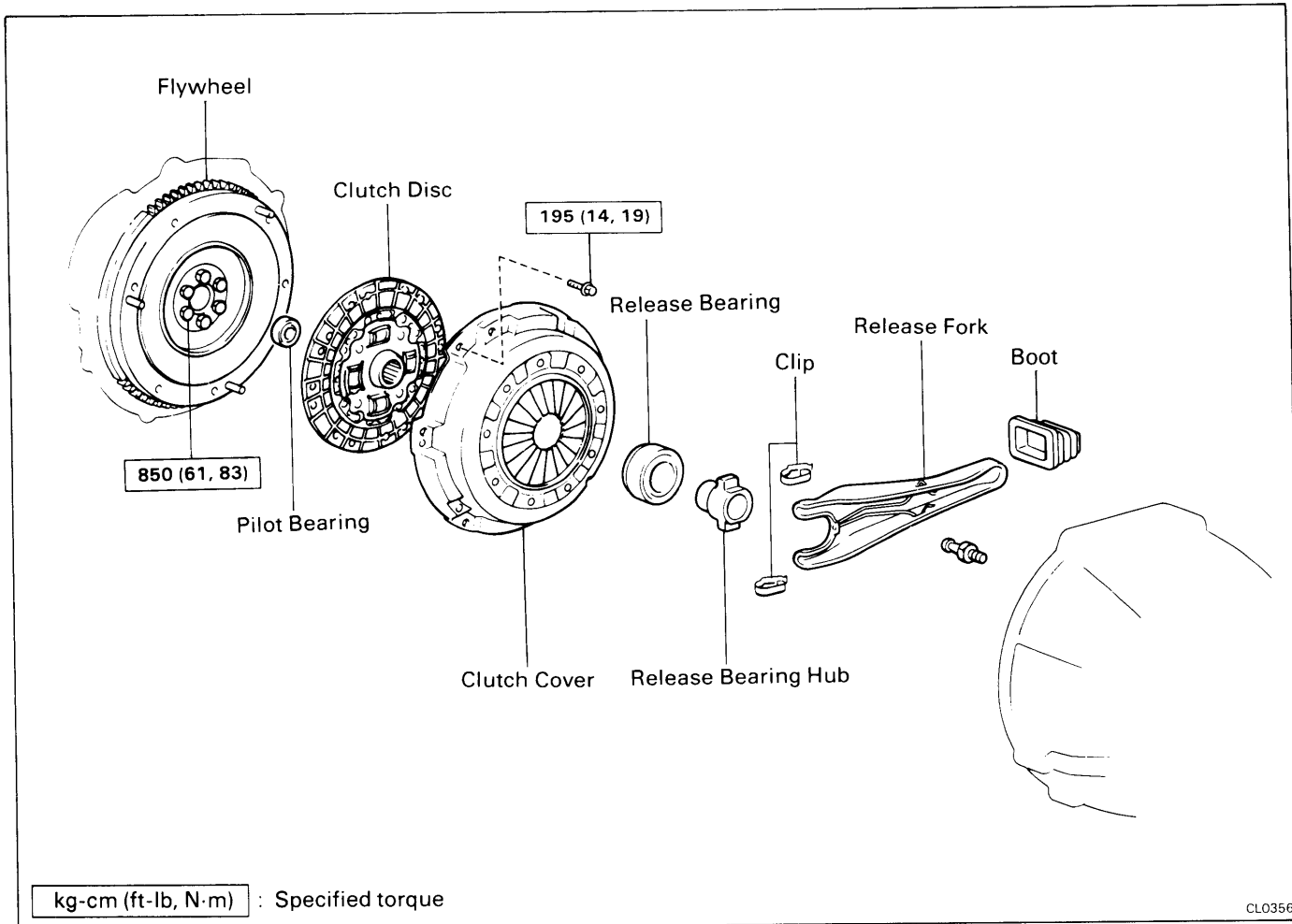

REMOVAL OF CLUTCH UNIT

1. REMOVE TRANSMISSION (See page MT-3)

NOTE: Do not drain the transmission oil.

2. REMOVE CLUTCH COVER AND DISC

- Place the matchmarks on the clutch cover and flywheel.
- Loosen each set bolt one turn at a time until the spring tension is released.
- Remove the set bolts and pull off the clutch cover and disc.

3. REMOVE RELEASE BEARING, FORK AND BOOT FROM TRANSMISSION

- Remove the clips and pull off the bearing and hub.
- Remove the fork and boot.

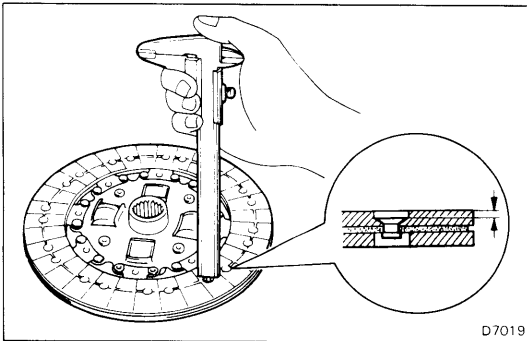

INSPECTION OF CLUTCH PARTS

1. INSPECT CLUTCH DISC FOR WEAR OR DAMAGE

Using calipers, measure the rivet head depth.

Minimum rivet depth: 0.3 mm (0.012 in.)

If a problem is found, replace the clutch disc.

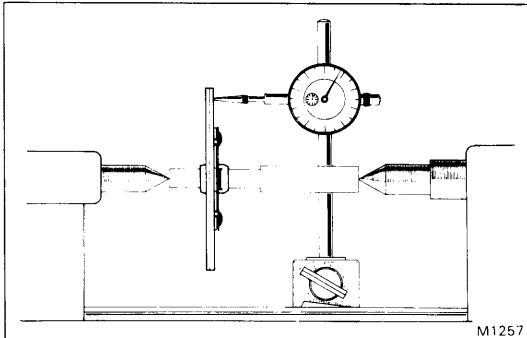

2. INSPECT CLUTCH DISC RUNOUT

Using a dial indicator, check the disc runout.

Maximum runout: 0.8 mm (0.031 in.)

If runout is excessive, replace the disc.

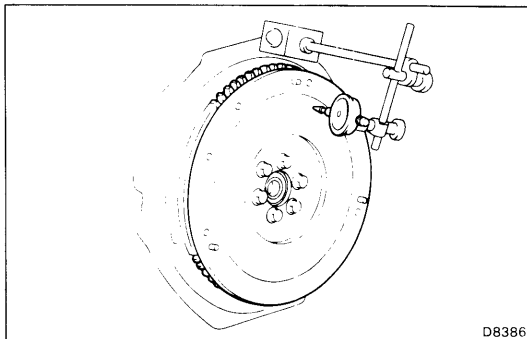

3. INSPECT FLYWHEEL RUNOUT

Using a dial indicator, check the flywheel runout.

Maximum runout: 0.2 mm (0.008 in.)

If runout is excessive, replace the flywheel.

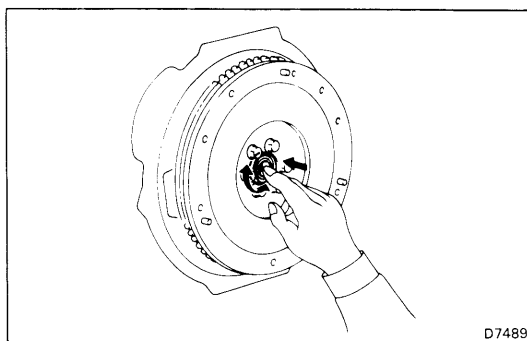

4. INSPECT PILOT BEARING

Turn the bearing by hand while applying force in the axial direction.

If the bearing sticks or has much resistance, replace the pilot bearing.

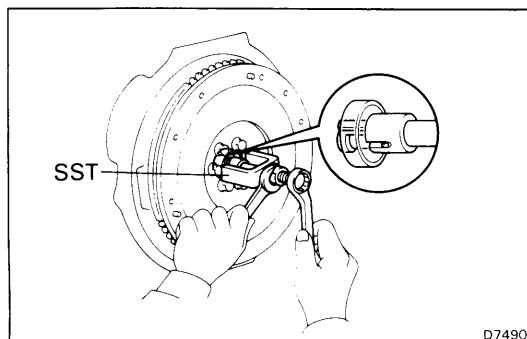

5. IF NECESSARY, REPLACE PILOT BEARING

(a) Using SST, remove the pilot bearing.

SST 09303-35011

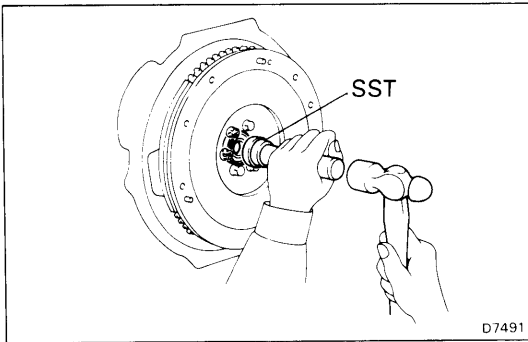

- (b) Using SST, install a new pilot bearing.
SST 09304-30012

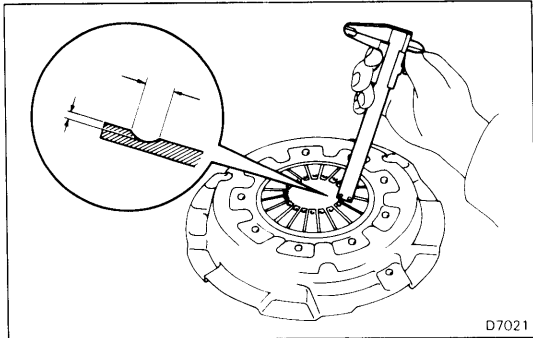

6. INSPECT DIAPHRAGM SPRING FOR WEAR

Using calipers, measure the diaphragm spring for depth and width of wear.

Limit: Depth 0.6 mm (0.024 in.)
Width 5.0 mm (0.197 in.)

If necessary, replace the clutch cover.

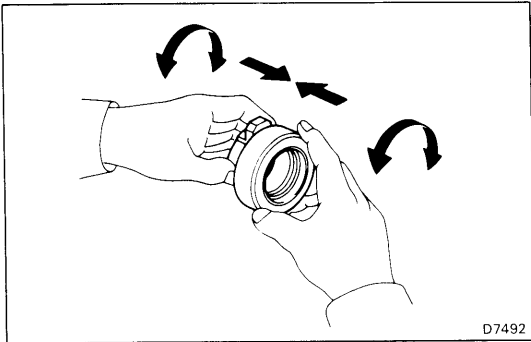

7. INSPECT RELEASE BEARING

Turn the bearing by hand while applying force in the axial direction.

If the bearing sticks or has much resistance, replace the release bearing.

NOTE: The bearing is permanently lubricated and requires no cleaning or lubrication.

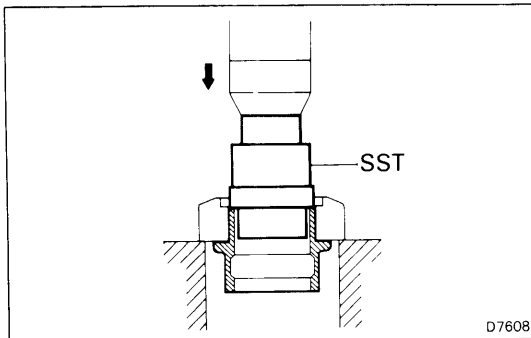

8. IF NECESSARY, REPLACE RELEASE BEARING

- (a) Using SST and a press, press out the release bearing hub from the release bearing.

SST 09315-00010

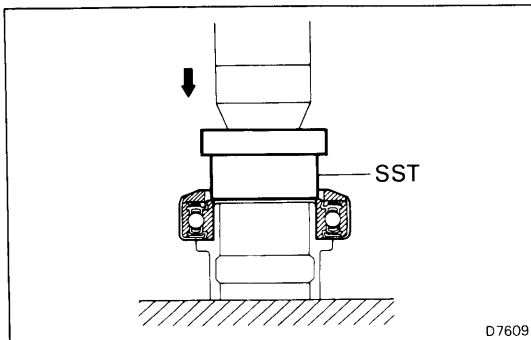

- (b) Using SST and a press, install a new release bearing to the release bearing hub.

SST 09315-00021

- (c) After installing the bearing, check that there is no drag on the bearing when it is turned under pressure.

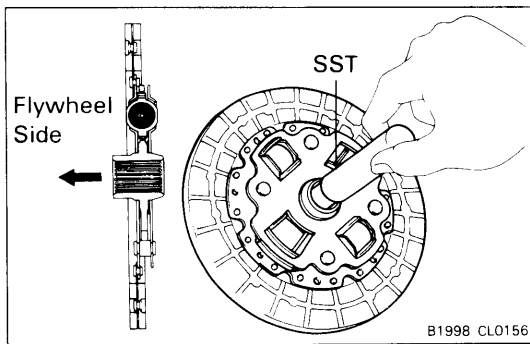

INSTALLATION OF CLUTCH UNIT

(See page CL-10)

1. INSTALL CLUTCH DISC ON FLYWHEEL

Using SST, install the disc on the flywheel.
SST 09301-20020

2. INSTALL CLUTCH COVER

- Align the matchmarks on the clutch cover and flywheel.
- Tighten the bolts evenly and gradually. Make several passes around the cover until the cover is snug. Torque the bolts.

Torque: 195 kg-cm (14 ft-lb, 19 N·m)

NOTE: Tighten the topmost bolt from the three near the knock pins first.

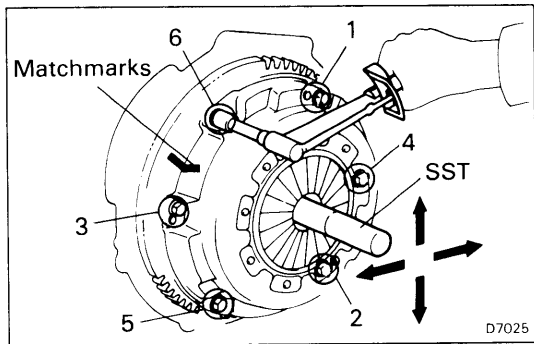

3. CHECK DIAPHRAGM SPRING TIP ALIGNMENT

Using a dial indicator and measuring point, check the diaphragm spring tip alignment.

Maximum non-alignment: 0.5 mm (0.020 in.)

If non-alignment is excessive, adjust as follows.

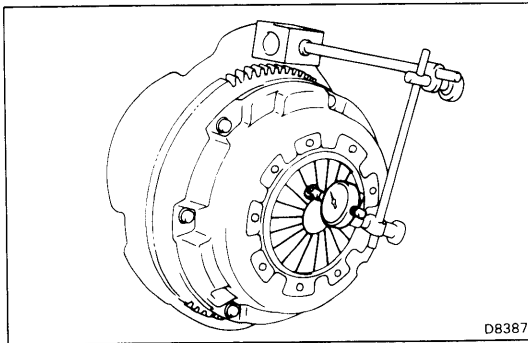

4. IF NECESSARY, ADJUST SPRINGS

Using SST, bend the springs until alignment is correct.

SST 09333-00013

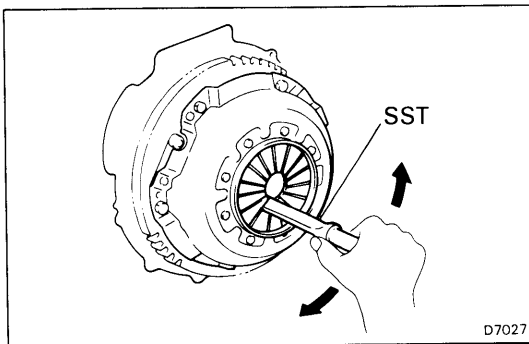

5. APPLY MOLYBDENUM DISULPHIDE LITHIUM BASE GREASE (NLGI NO. 2) OR MP GREASE

- Apply molybdenum disulphide lithium base grease to the following parts:

- Release fork and hub contact point
- Release fork and push rod contact point
- Release fork pivot point

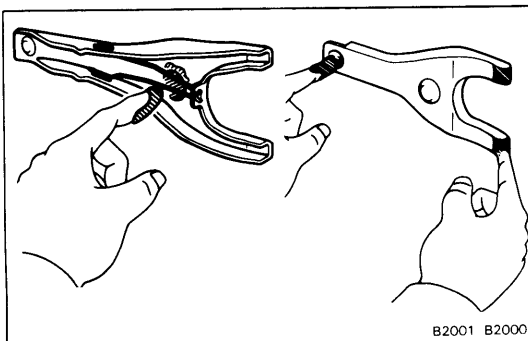

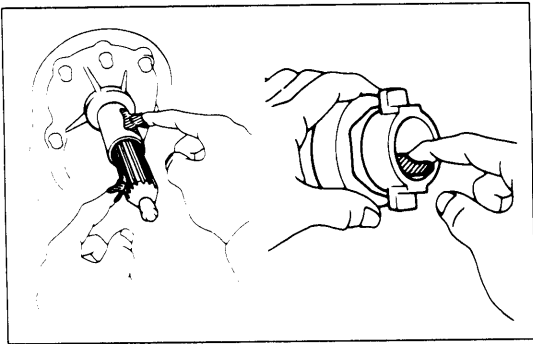

- Clutch disc spline
- Release bearing hub inside groove

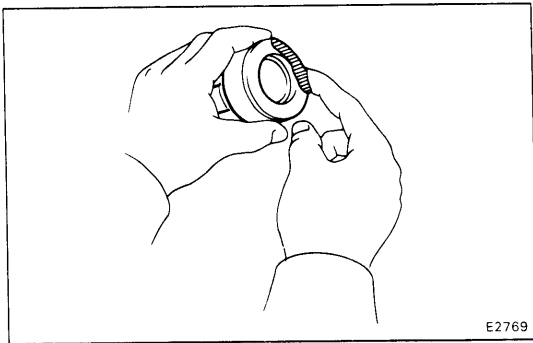

- (b) Apply MP grease to the front surface of the release bearing.

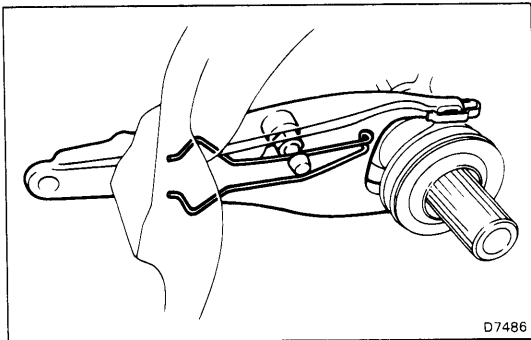

6. INSTALL BOOT, FORK AND RELEASE BEARING ON TRANSMISSION

7. INSTALL TRANSMISSION
(See page MT-36)