CHARGING SYSTEM

	Page
PRECAUTIONS	CH-2
TROUBLESHOOTING	CH-2
ON-VEHICLE INSPECTION	CH-3
ALTERNATOR	CH-6
IGNITION MAIN RELAY	CH-14

PRECAUTIONS

1. Check that the battery cables are connected to the correct terminals.
2. Disconnect the battery cables when the battery is given a quick charge.
3. Do not perform tests with a high voltage insulation resistance tester.
4. Never disconnect the battery when the engine is running.

TROUBLESHOOTING

Problem	Possible cause	Remedy	Page
Discharge warning light does not light with ignition ON and engine off	Fuse blown	Check "IGN", "CHARGE" and "ENGINE" fuses	CH-6
	Light burned out	Replace light	
	Wiring connection loose	Tighten loose connections	
	IC regulator faulty	Replace IC regulator	
Discharge warning light does not go out with engine running (battery requires frequent recharging)	Drive belt loose or worn	Adjust or replace drive belt	CH-3
	Battery cables loose, corroded or worn	Repair or replace cables	CH-4
	Fuse blown	Check "ENGINE" fuse	
	Fusible link blown	Replace fusible link	
	IC regulator or alternator faulty	Check charging system	
	Wiring faulty	Repair wiring	

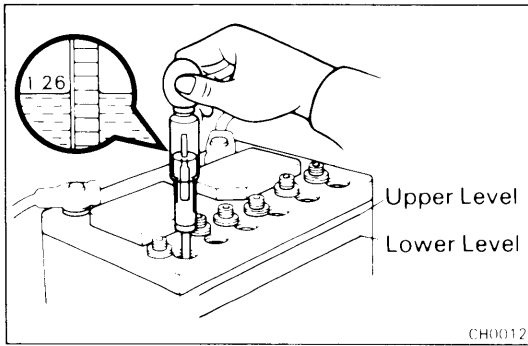

CH0012

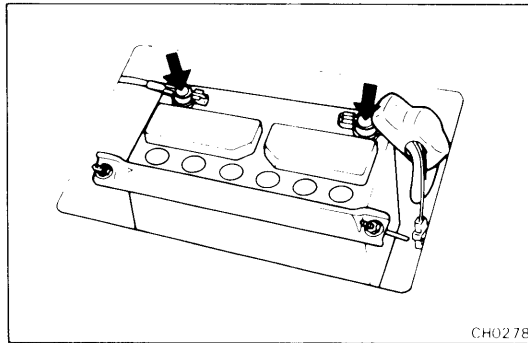

CH0278

ON-VEHICLE INSPECTION

1. CHECK BATTERY SPECIFIC GRAVITY AND ELECTROLYTE LEVEL

- (a) Check the specific gravity of each cell.

Standard specific gravity:

1.25 – 1.27 when fully charged at 20°C (68°F)

- (b) Check the electrolyte quantity of each cell.

If insufficient, refill with distilled (or purified) water.

2. CHECK BATTERY TERMINALS, FUSIBLE LINKS AND FUSES

- (a) Check that the battery terminals are not loose or corroded.

- (b) Check the fusible link and fuses for continuity.

Fusible link:

0.5G

1.25B

2.0L

AM1 80A

AM2 30A

Fuse:

CHARGE 7.5A

ENGINE 15A

IGN 7.5A

3. INSPECT DRIVE BELT

- (a) Visually check the belt for separation of the adhesive rubber above and below the core, separating from the belt side, severed core, separation of the rib from the adhesive rubber, cracking or separation of the ribs, torn or worn ribs or cracks in the inner ridges of the ribs.

If the belt has any of the above defects, replace it.

- (b) Using a belt tension gauge, check the drive belt tension.

Belt tension gauge:

Nippondenso BTG-20 (95506-00020) or

Borroughs No. BT-33-73F

Drive belt tension: New belt 175 ± 5lb

Used belt 115 ± 20lb

If the belt tension is not within specification, adjust it.

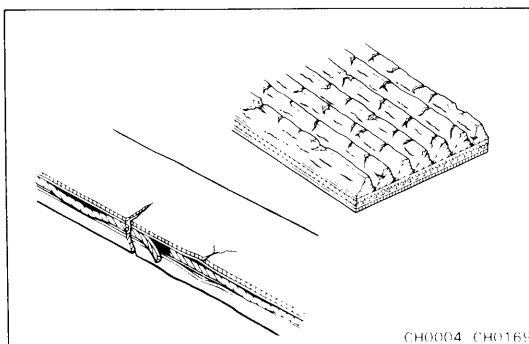

CH0004, CH0169

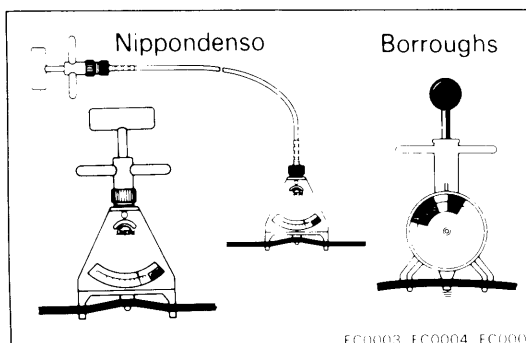

FC0003, FC0004, FC0001

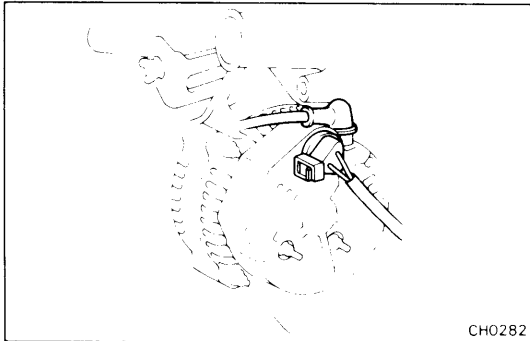
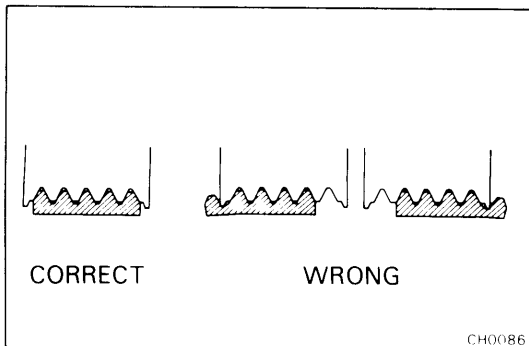
**NOTE:**

- “New belt” refers to a belt which has been used less than 5 minutes on a running engine.
- “Used belt” refers to a belt which has been used on a running engine for 5 minutes or more.
- After installing the drive belt, check that it fits properly in the ribbed grooves.
- Check by hand to confirm that the belt has not slipped out of the groove on the bottom of the crank pulley.
- After installing the belt, run the engine for about 5 minutes and then recheck the tension.

4. VISUALLY CHECK ALTERNATOR WIRING AND LISTEN FOR ABNORMAL NOISES

- (a) Check that the wiring is in good condition.
- (b) Check that there is no abnormal noise from the alternator while the engine is running.

5. CHECK CHARGE LIGHT CIRCUIT

- (a) Warm up the engine and then turn it off.
- (b) Turn off all accessories.
- (c) Turn the ignition switch to “ON”. Check that the charge light is lit.
- (d) Start the engine. Check that the light goes out.

If the light does not go off as specified, troubleshoot the charge light circuit.

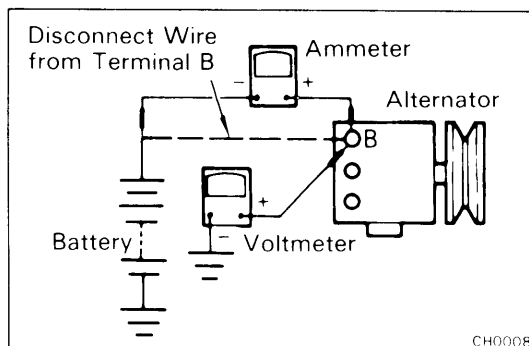
**6. CHECK CHARGING CIRCUIT WITHOUT LOAD**

NOTE: If a battery/alternator tester is available, connect the tester to the charging circuit as per manufacturer’s instructions.

- (a) If a tester is not available, connect a voltmeter and ammeter to the charging circuit as follows:
 - Disconnect the wire from terminal B of the alternator and connect it to the negative (–) probe of the ammeter.
 - Connect the test probe from the positive (+) terminal of the ammeter to terminal B of the alternator.
 - Connect the positive (+) probe of the voltmeter to terminal B of the alternator.
 - Ground the negative (–) probe of the voltmeter.

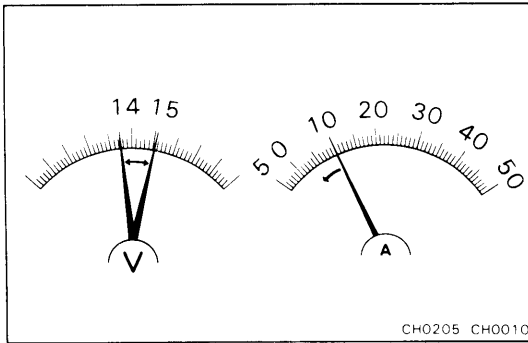

(b) Check the charging circuit as follows:

With the engine running from idling to 2,000 rpm, check the reading on the ammeter and voltmeter.

Standard amperage: 10A or less

Standard voltage: 13.5 – 15.1 V at 25°C (77°F)

If the voltage reading is not within standard voltage, replace the IC regulator.

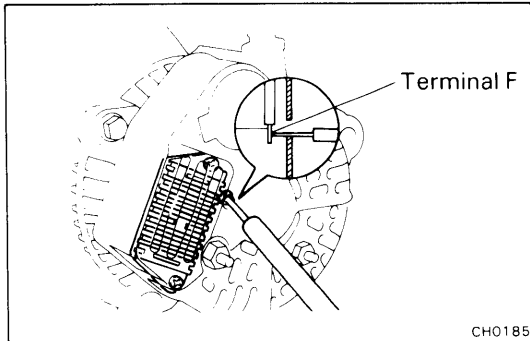

If the voltage reading is less than standard voltage, check the IC regulator and alternator as follows:

- With terminal F grounded, start the engine and check the voltage reading of terminal B.

- If the voltage reading is greater than standard voltage, replace the IC regulator.

- If the voltage reading is less than standard voltage, check the alternator.

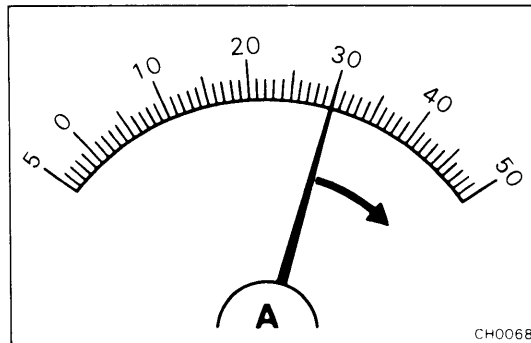
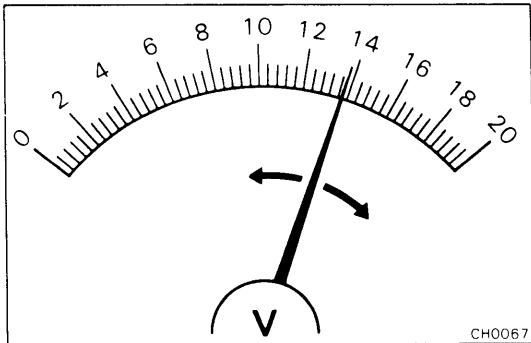

7. CHECK CHARGING CIRCUIT WITH LOAD

(a) With the engine running at 2,000 rpm, turn on the high beam headlights and place the heater fan control switch on "HI".

(b) Check the reading on the ammeter.

Standard amperage: 30A or more

If the ammeter reading is less than 30A, repair the alternator. (See page CH-6)

NOTE: With the battery fully charged, the indication will sometimes be less than 30A.

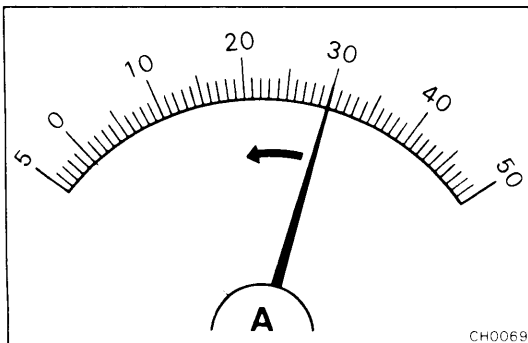

ALTERNATOR COMPONENTS

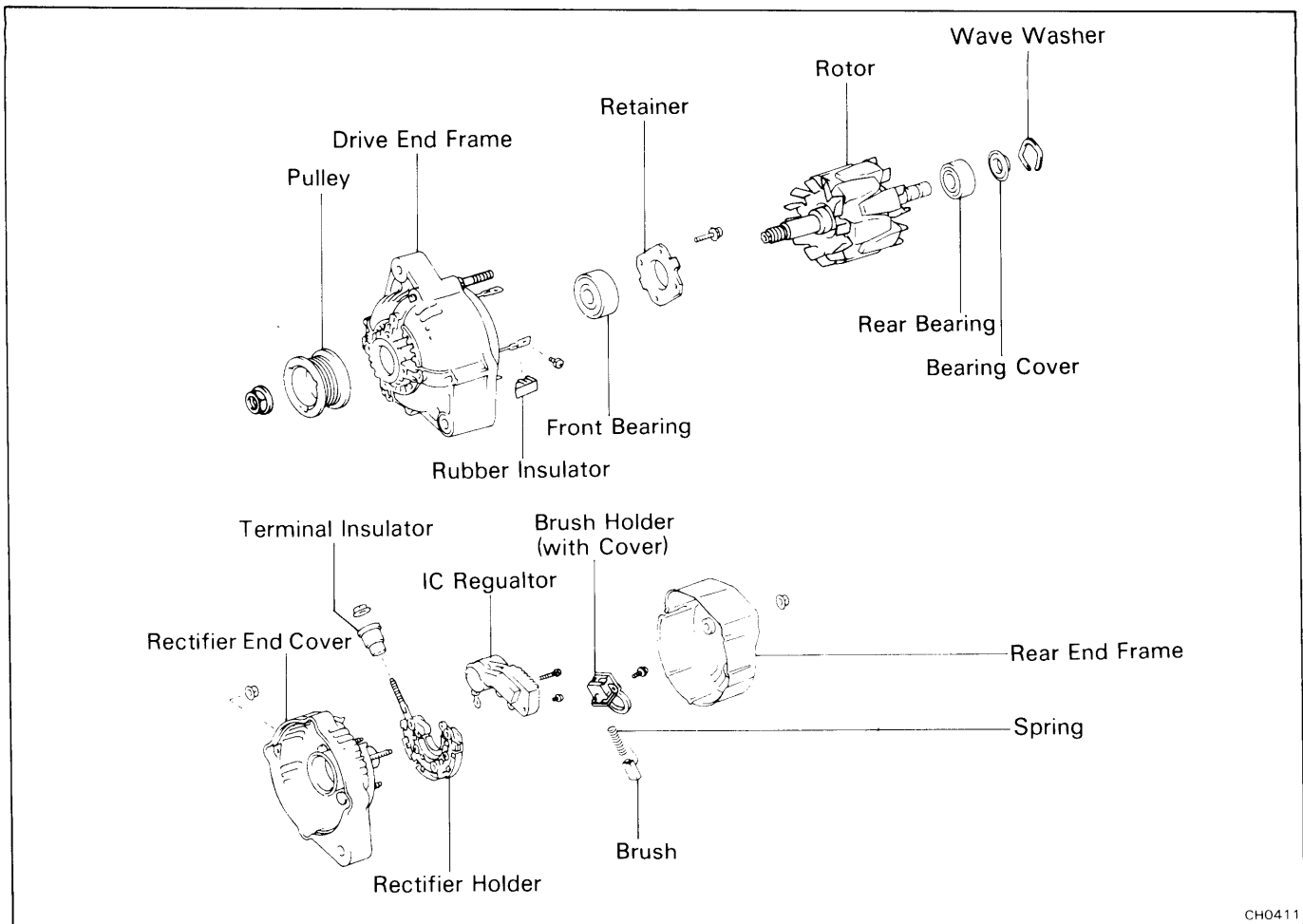

CH0411

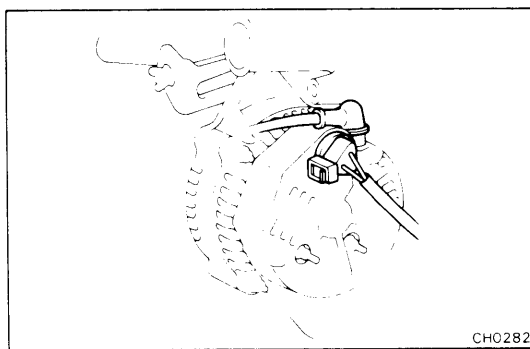

CH0282

REMOVAL OF ALTERNATOR

1. DISCONNECT CABLE FROM NEGATIVE TERMINAL OF BATTERY
2. DISCONNECT CONNECTOR AND WIRE FROM ALTERNATOR
3. DISCONNECT DRIVE BELT FROM ALTERNATOR
 - (a) Loosen the adjusting lock, pivot and adjusting bolts.
 - (b) Disconnect the drive belt.
4. REMOVE ALTERNATOR
 - (a) Remove the adjusting lock and pivot bolts.
 - (b) Remove the alternator.

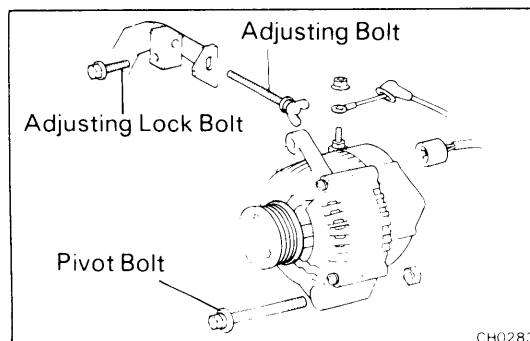

CH0283

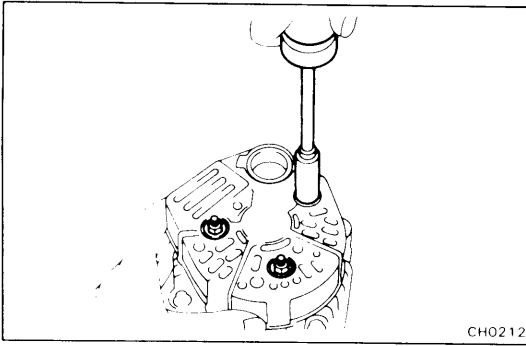

CH0212

DISASSEMBLY OF ALTERNATOR

(See page CH-6)

1. REMOVE REAR END COVER

- (a) Remove the nut and terminal insulator.
- (b) Remove the three nuts and end cover.

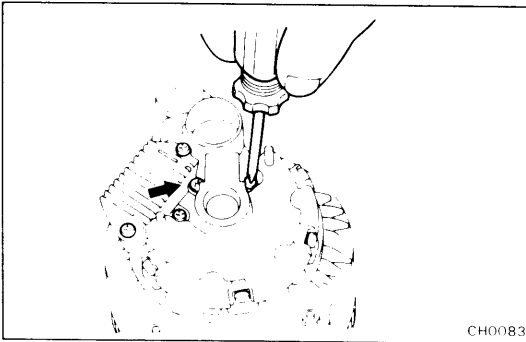

CH0083

2. REMOVE BRUSH HOLDER

Remove the two screws, brush holder and cover.

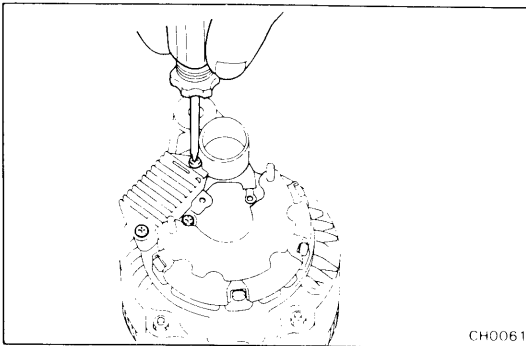

CH0061

3. REMOVE IC REGULATOR

Remove the three screws and IC regulator.

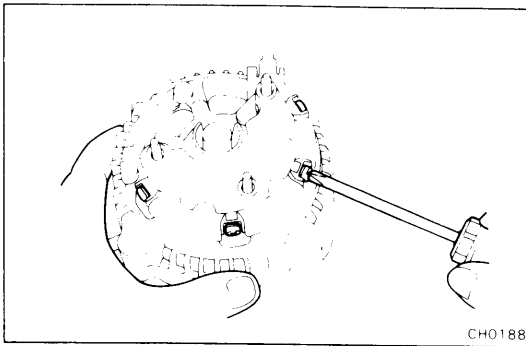

CH0188

4. REMOVE RECTIFIER HOLDER

- (a) Remove the four screws and rectifier holder.
- (b) Remove the four rubber insulators.

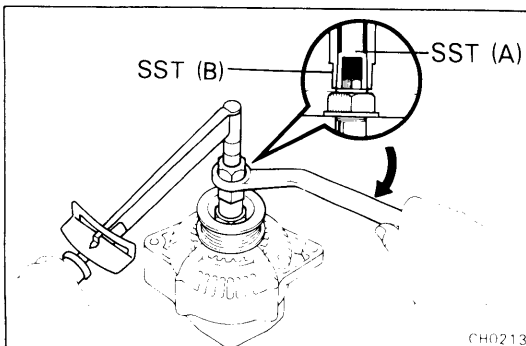

CH0213

5. REMOVE PULLEY

- (a) Hold SST (A) with a torque wrench, and tighten SST (B) clockwise to the specified torque.

SST 09820-63010

Torque: 400 kg-cm (29 ft-lb, 39 N·m)

- (b) Check that SST (A) is secured to the rotor shaft.

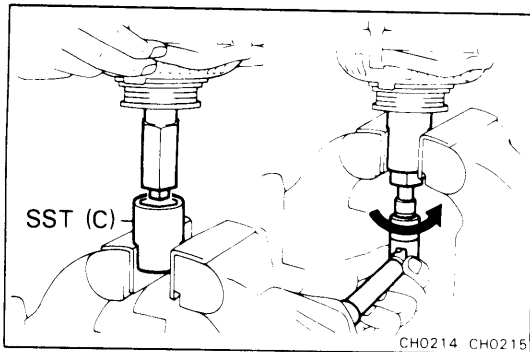

- (c) As shown in the figure, mount SST (C) in a vise, and install the alternator to SST (C).
- (d) To loosen the pulley nut turn SST (A) in the direction shown in the figure.

CAUTION: To prevent damage to the rotor shaft, do not loosen the pulley nut more than one-half of a turn.

- (e) Remove the alternator from SST (C).
- (f) Turn SST (B) and remove SSTs (A and B).
- (g) Remove the pulley nut and pulley.

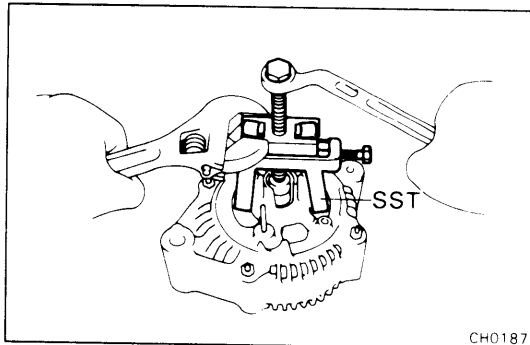

6. REMOVE RECTIFIER END FRAME

- (a) Remove the four nuts.
- (b) Using SST, remove the rectifier end frame.
SST 09286-46011

7. REMOVE ROTOR FROM DRIVE END FRAME

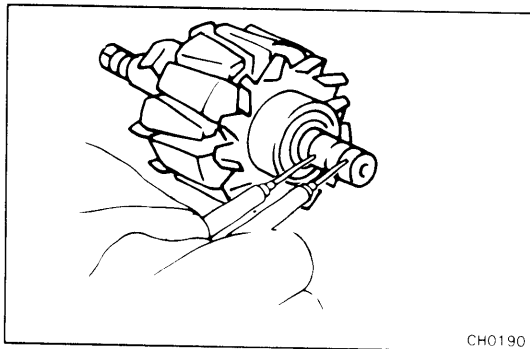

INSPECTION AND REPAIR OF ALTERNATOR Rotor

1. INSPECT ROTOR FOR OPEN CIRCUIT

Using an ohmmeter, check that there is continuity between the slip rings.

Standard resistance (cold): 2.8 – 3.0 Ω

If there is no continuity, replace the rotor.

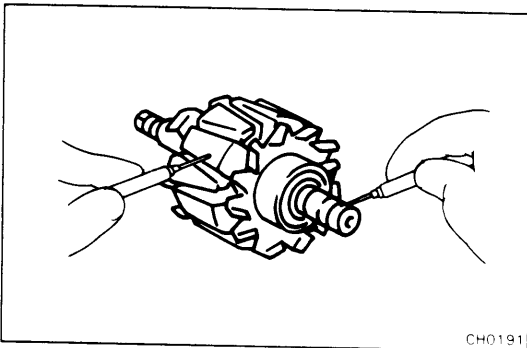

2. INSPECT ROTOR FOR GROUND

Using an ohmmeter, check that there is no continuity between the slip ring and the rotor.

If there is continuity, replace the rotor.

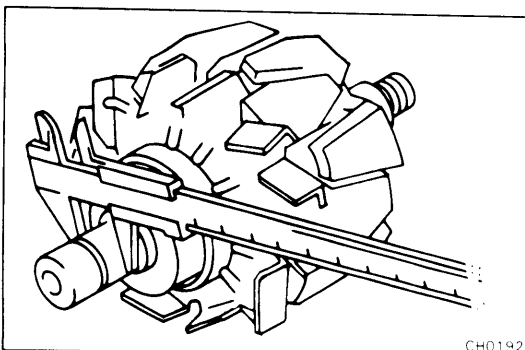

3. INSPECT SLIP RINGS

- (a) Check that the slip rings are not rough or scored. If rough or scored, replace the rotor.

- (b) Using calipers, measure the slip ring diameters.

Standard diameter: 14.2 – 14.4 mm
(0.559 – 0.567 in.)

Minimum diameter: 12.8 mm (0.504 in.)

If the diameter is less than minimum, replace the rotor.

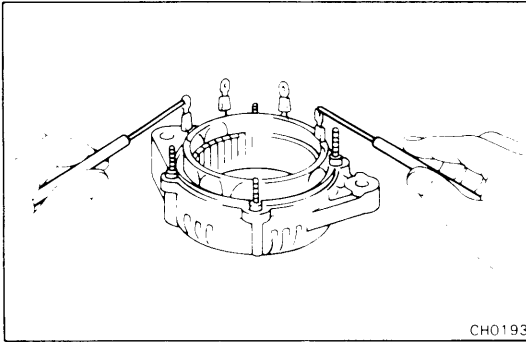

Stator

1. INSPECT STATOR FOR OPEN CIRCUIT

Using an ohmmeter, check that there is continuity between the coil leads.

If there is no continuity, replace the drive end frame assembly.

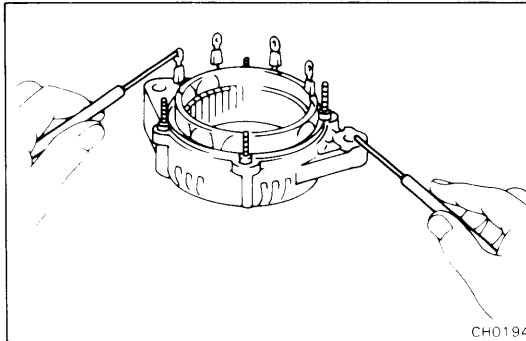

2. INSPECT STATOR FOR GROUND

Using an ohmmeter, check that there is no continuity between the coil leads and drive end frame.

If there is continuity, replace the drive end frame assembly.

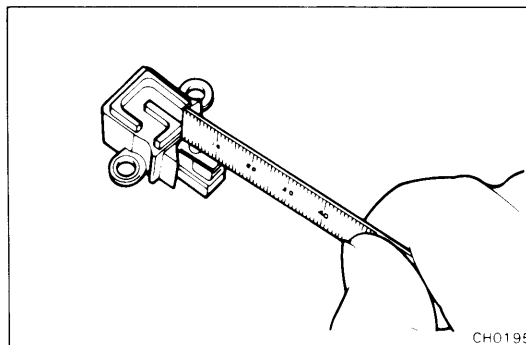

Brushes

1. INSPECT EXPOSED BRUSH LENGTH

(a) Using a scale, measure the exposed brush length.

Standard exposed length: 10.5 mm (0.413 in.)

Minimum exposed length: 1.5 mm (0.0059 in.)

If the exposed length is less than minimum, replace the brushes.

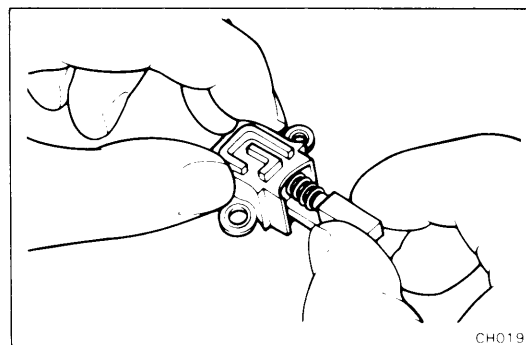

2. IF NECESSARY, REPLACE BRUSHES

(a) Unsolder and remove the brush and spring.

(b) Run the wire of the brush through the hole in the brush holder, and insert the spring and brush into the brush holder.

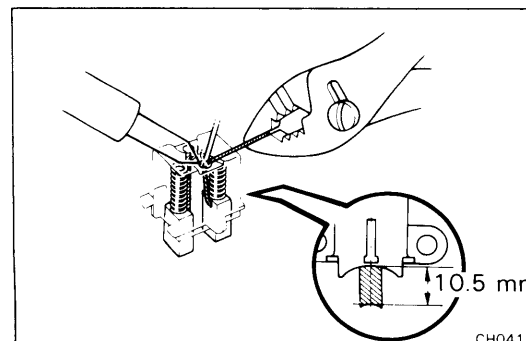

(c) Solder the brush wire to the brush holder at the exposed length.

Exposed length: 10.5 mm (0.413 in.)

(d) Check that the brush moves smoothly in the brush holder.

(e) Cut off the excess wire.

(f) Apply insulation paint to the soldered point.

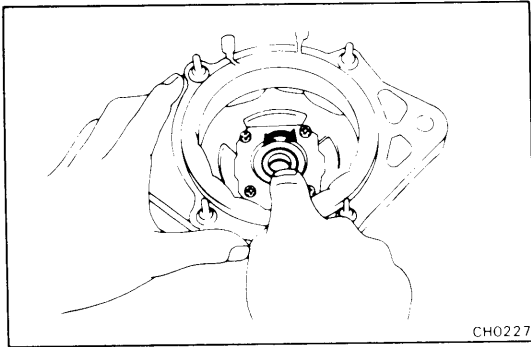

Bearings

1. INSPECT FRONT BEARING

Check that the bearing is not rough or worn.

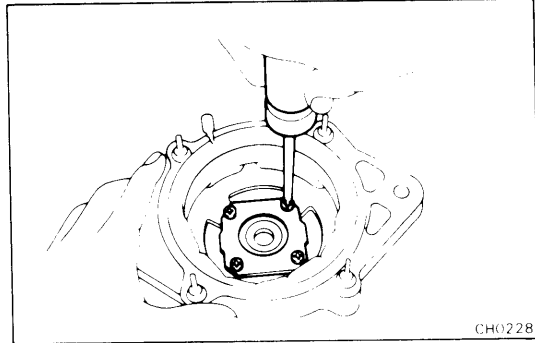

2. IF NECESSARY, REPLACE FRONT BEARING

(a) Remove the four screws, bearing retainer and bearing.

(b) Install the bearing.

(c) Align the claws of the bearing retainer with the slots of the drive end frame.

(d) Install the bearing retainer with the four screws.

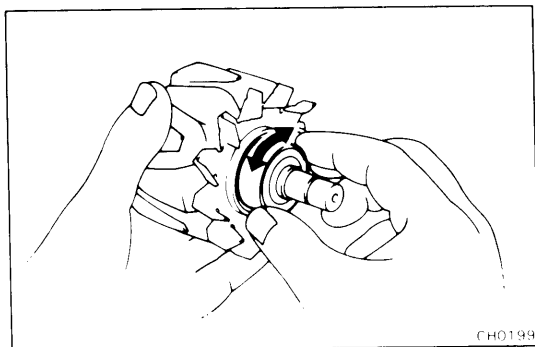
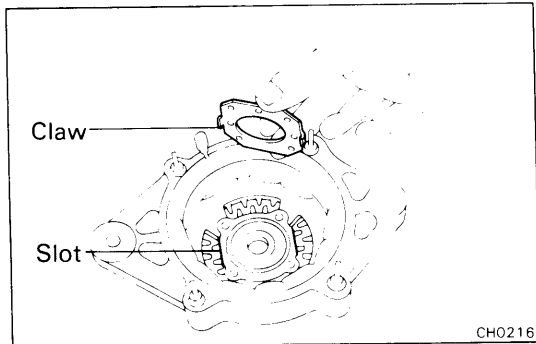

3. INSPECT REAR BEARING

Check that the bearing is not rough or worn.

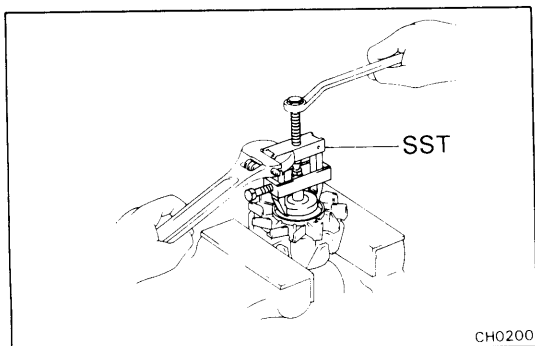

4. IF NECESSARY, REPLACE REAR BEARING

(a) Using SST, remove the bearing cover and bearing.
SST 09820-00021

CAUTION: Be careful not to damage the fan.

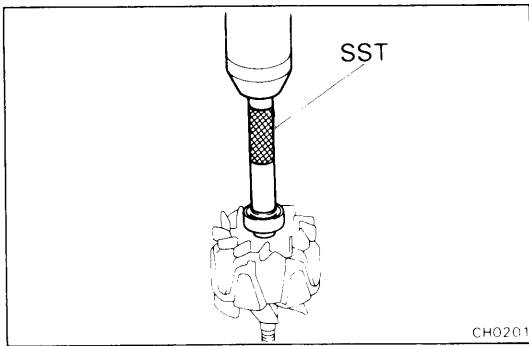

- (b) Using SST and a press, press in a new bearing and bearing cover.

SST 09285-76010

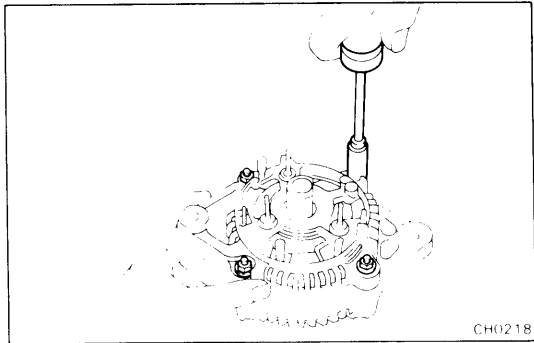

ASSEMBLY OF ALTERNATOR

(See page CH-6)

1. INSTALL ROTOR TO DRIVE END FRAME

2. INSTALL RECTIFIER END FRAME

- (a) Using a plastic-faced hammer, lightly tap in the end frame, together with the wave washer.
 (b) Install the four nuts.

3. INSTALL PULLEY

- (a) Install the pulley to the rotor shaft by tightening the pulley nut by hand.
 (b) Hold SST (A) with a torque wrench, and tighten SST (B) clockwise to the specified torque.

SST 09820-63010

Torque: 400 kg-cm (29 ft-lb, 39 N·m)

- (c) Check that SST (A) is secured to the pulley shaft.

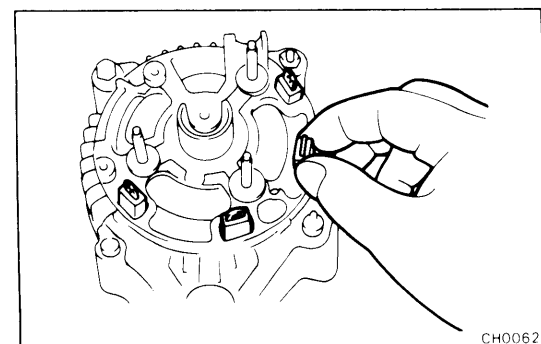
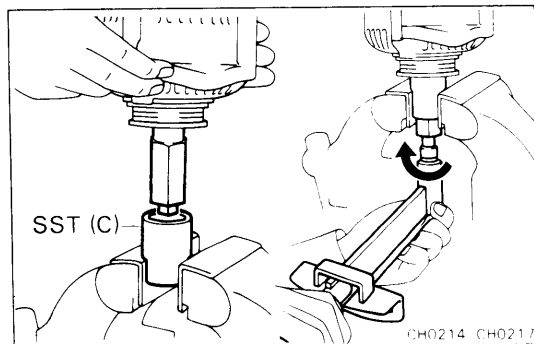
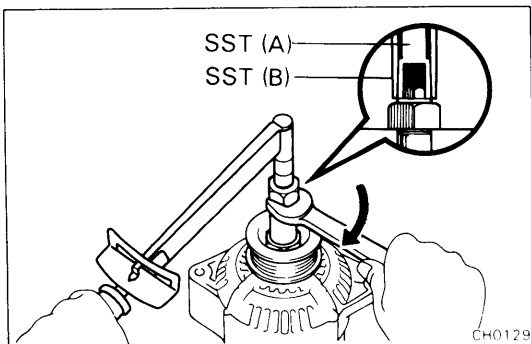

- (d) As shown in the figure, mount SST (C) in a vise, and install the alternator to SST (C).
 (e) To torque the pulley nut turn SST (A) in the direction shown in the figure.

Torque: 1,125 kg-cm (81 ft-lb, 110 N·m)

- (f) Remove the alternator from SST (C).
 (g) Turn SST (B) and remove SSTs (A and B).

4. INSTALL RECTIFIER HOLDER

- (a) Install the four rubber insulators on the lead wires.

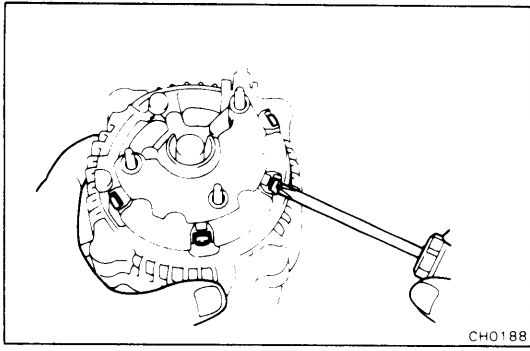

- (b) Install the rectifier with the four screws.

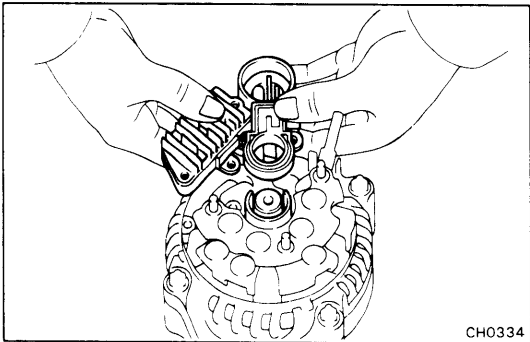

5. INSTALL BRUSH HOLDER AND IC REGULATOR

- (a) Install the brush holder cover to the brush holder.
 (b) Install the IC regulator together with the brush holder horizontally as shown.

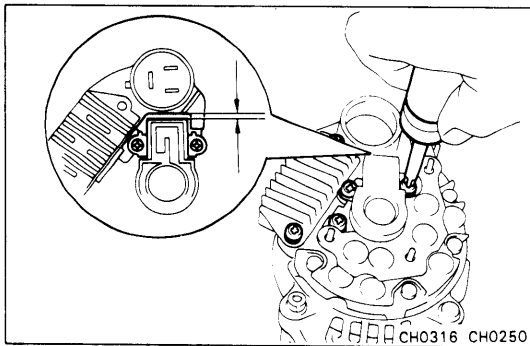

- (c) Install the five screws.
 (d) Check the clearance between the brush holder and connector is 1 mm (0.04 in.) or more.

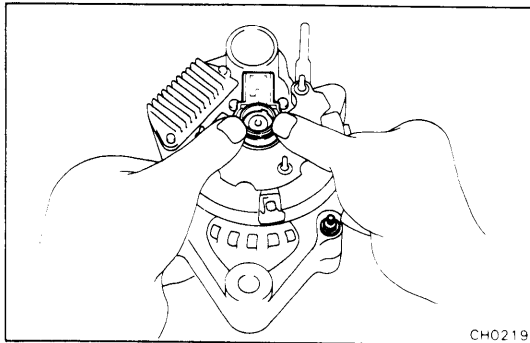

- (e) Install the brush holder cover to the rear end frame.

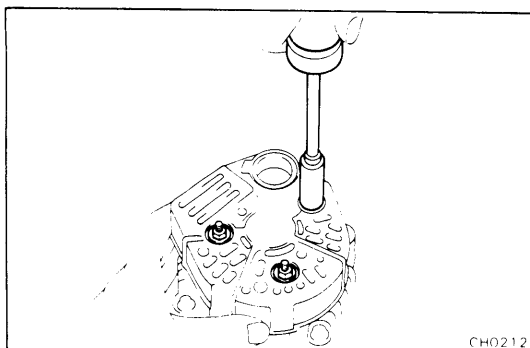

6. INSTALL REAR END COVER

- (a) Install the end cover with the three nuts.
 (b) Install the terminal insulator with the nut.

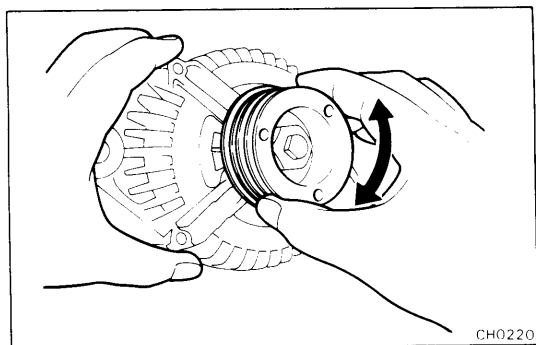

7. MAKE SURE ROTOR ROTATES SMOOTHLY

INSTALLATION OF ALTERNATOR

1. INSTALL ALTERNATOR

Mount the alternator on the engine bracket with the pivot and adjusting lock bolts. Do not tighten the bolts yet.

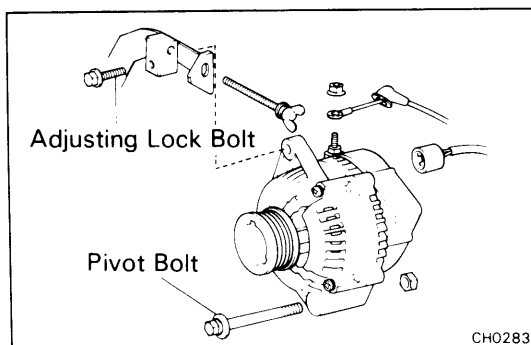

2. INSTALL AND ADJUST DRIVE BELT

- (a) Install the drive belt.
- (b) Move the alternator over by hand until the belt tightens, then lightly tighten the adjusting bolt until it touches the engine bracket.

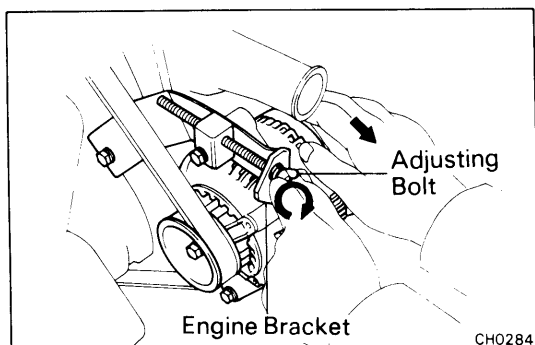

- (c) Tighten the adjusting bolt the specified number of revolutions.

Adjusting bolt revolutions:

New belt 8 revolutions

Used belt 5 revolutions

- (d) Check the drive belt tension. (See page CH-3)

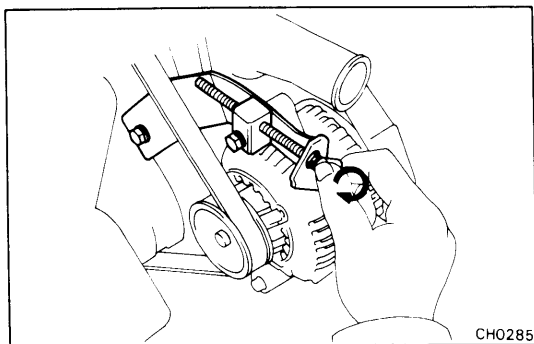

3. CONNECT CONNECTOR AND WIRE TO ALTERNATOR

4. CONNECT CABLE TO NEGATIVE TERMINAL OF BATTERY

5. PERFORM ON-VEHICLE INSPECTION (See steps 5 to 7 on pages CH-4 to 6)

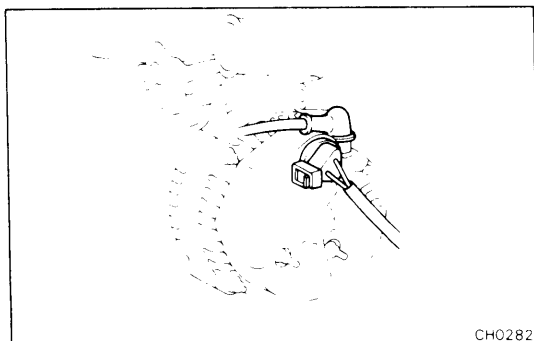

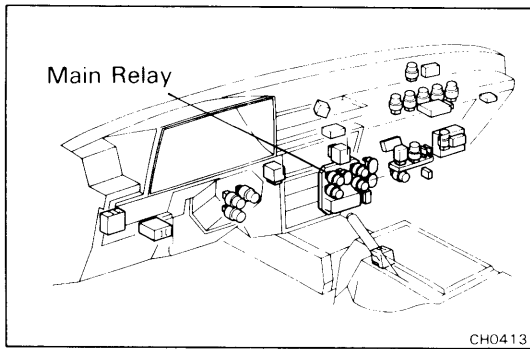

IGNITION MAIN RELAY

LOCATION: Under the instrument panel in the relay box.

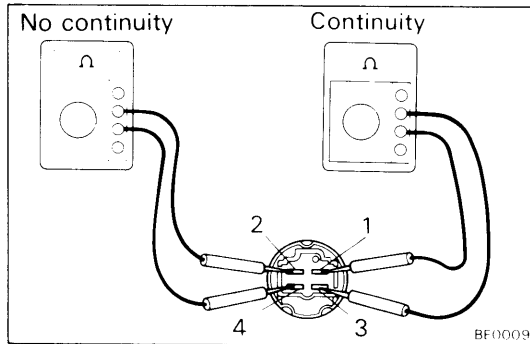

INSPECTION OF IGNITION MAIN RELAY

1. INSPECT RELAY CONTINUITY

- (a) Using an ohmmeter, check that there is continuity between terminals 1 and 3.
- (b) Check that there is no continuity between terminals 2 and 4.

If continuity is not as specified, replace the relay.

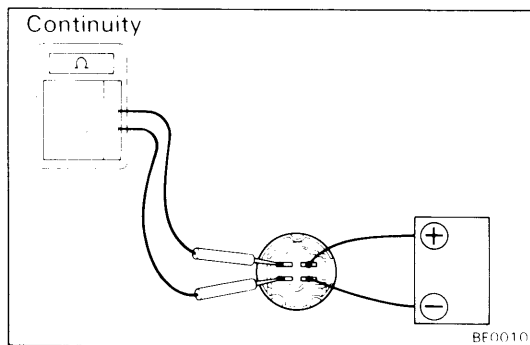

2. INSPECT RELAY OPERATION

- (a) Apply battery voltage across terminals 1 and 3.
- (b) Using an ohmmeter, check that there is continuity between terminals 2 and 4.

If operation is not as specified, replace the relay.