MAINTENANCE

	Page
MAINTENANCE SCHEDULE	MA-2
MAINTENANCE OPERATIONS	MA-4
GENERAL MAINTENANCE	MA-14



GENERAL NOTES:

- Every service item in the periodic maintenance list must be performed.
- Failure to do even one item can cause the engine to run poorly and increase exhaust emissions.

MAINTENANCE SCHEDULE

Maintenance operations: A = Check and adjust if necessary;
 R = Replace, change or lubricate;
 I = Inspect and correct or replace if necessary

NORMAL CONDITION SCHEDULE

System	Service interval (Odometer reading or months, whichever, comes first)	Maintenance services beyond 60,000 miles (96,000 km) should be performed at the same intervals shown in each maintenance schedule.						See page (item No.)	
		Miles × 1,000	10	20	30	40	50		60
Maintenance items		Km × 1,000	16	32	48	64	80	96	
		Months	12	24	36	48	60	72	
ENGINE	Drive belts ⁽¹⁾				I			I	MA-4 (item 1)
	Engine oil and filter★		R	R	R	R	R	R	MA-5 (item 5)
	Engine coolant ⁽²⁾							R	MA-5 (item 6)
FUEL	Exhaust pipes and mountings				I			I	MA-6 (item 10)
	Idle speed ⁽³⁾		A		A			A	MA-7 (item 12)
	Air filter★				R			R	MA-5 (item 4)
	Fuel line and connections				I			I	MA-6 (item 9)
IGNITION	Fuel filler cap gasket							R	MA-6 (item 8)
	Spark plugs (Platinum tipped)*							R	MA-4 (item 2)
EVAP	Charcoal canister	Calif. only						I	MA-6 (item 7)
EXHAUST	Oxygen sensor* ⁽⁴⁾							R	MA-7 (item 11)
BRAKES	Brake lining and drums			I		I		I	MA-8 (item 14)
	Brake pads and discs			I		I		I	MA-8 (item 15)
	Brake line pipes and hoses			I		I		I	MA-8 (item 13)
CHASSIS	Steering linkage			I		I		I	MA-9 (item 16)
	Drive shaft boots	4WD only		I		I		I	MA-9 (item 18)
	Ball joints and dust covers			I		I		I	MA-9 (item 19)
	Front wheel bearing and thrust bush grease (4WD)					R			MA-10 (item 20)
	Steering knuckle and chassis grease ⁽⁵⁾	4WD only		R		R		R	MA-10 (item 21)
	Propeller shaft grease ⁽⁵⁾	4WD only		R		R		R	MA-10 (item 21)
	Automatic transmission, manual transmission, transfer (4WD), differential and steering gear box oil			I		I		I	MA-9 (item 17) MA-10 (item 22)
Bolts and nuts on chassis and body			I		I		I	MA-12 (item 25)	

Maintenance services indicated by a star (★) or asterisk (*) are required under the terms of the Emission Control Systems Warranty (ECSW). See Owner's Guide or Warranty Booklet for complete warranty information.

★ For vehicles sold in California

* For vehicles sold outside California

NOTE:

- (1) After 60,000 miles (96,000 km) or 72 months, inspect every 10,000 miles (16,000 km) or 12 months.
- (2) After 60,000 miles (96,000 km) or 72 months, replace every 30,000 miles (48,000 km) or 36 months.
- (3) After 60,000 miles (96,000 km) or 72 months, adjust every 30,000 miles (48,000 km) or 36 months.
- (4) Replace at 60,000 miles (96,000 km) or 72 months only.
- (5) If the upper suspension arm and propeller shaft has been immersed in water, it should be re-greased within daily.

Follow the severe condition schedule if vehicle is operated mainly under one or more of the following severe conditions:

- Towing a trailer, using a camper or car top carrier.
- Repeat short trips less than 5 miles (8 km) and outside temperatures remain below freezing.
- Extensive idling and/or low speed driving for a long distance such as police, taxi or door-to-door delivery use.
- Operating on dusty, rough, muddy or salt spread roads.

SEVERE CONDITION SCHEDULE

System	Service interval (Odometer reading or months, whichever, comes first)	Maintenance services beyond 60,000 miles (96,000 km) should be performed at the same intervals shown in each maintenance schedule.												See page (item No.)	
		Miles × 1,000	5	10	15	20	25	30	35	40	45	50	55		60
		Km × 1,000	8	16	24	32	40	48	56	64	72	80	88		96
		Months	6	12	18	24	30	36	42	48	54	60	66		72
ENGINE	Drive belts ⁽¹⁾							I						I	MA-4 (item 1)
	Engine oil and oil filter★		R	R	R	R	R	R	R	R	R	R	R	R	MA-5 (item 5)
	Engine coolant ⁽²⁾													R	MA-5 (item 6)
	Exhaust pipes and mountings				I			I			I			I	MA-6 (item 10)
FUEL	Idle speed ⁽³⁾			A				A						A	MA-7 (item 12)
	Air filter★ ⁽⁶⁾		I	I	I	I	I	R	I	I	I	I	I	R	MA-5 (item 3, 4)
	Fuel line and connections							I						I	MA-6 (item 9)
	Fuel filler cap gasket													R	MA-6 (item 8)
IGNITION	Spark plugs (Platinum tipped)*													R	MA-4 (item 2)
EVAP	Charcoal canister	Calif. only												I	MA-6 (item 7)
EXHAUST	Oxygen sensor ⁽⁴⁾													R	MA-7 (item 11)
BRAKES	Brake linings and drums			I		I		I		I		I		I	MA-8 (item 14)
	Brake pads and discs			I		I		I		I		I		I	MA-8 (item 15)
	Brake line pipes and hoses					I				I				I	MA-8 (item 13)
CHASSIS	Steering linkage			I		I		I		I		I		I	MA-9 (item 16)
	Drive shaft boots			I		I		I		I		I		I	MA-9 (item 18)
	Ball joints and dust covers			I		I		I		I		I		I	MA-9 (item 19)
	Front wheel bearing and thrust bush grease (4WD)									R					MA-10 (item 20)
	Steering knuckle and chasis grease ⁽⁵⁾		R		R		R		R		R		R		MA-10 (item 21)
	Propeller shaft grease ⁽⁵⁾		R		R		R		R		R		R		MA-10 (item 21)
	Automatic transmission, manual transmission, transfer (4WD), differential and steering gear box oil ⁽⁸⁾						R				R			R	MA-9 (item 17) MA-11 (item 23) MA-12 (item 24)
Bolts and nuts on chassis and body ⁽⁷⁾			I		I		I		I		I		I	MA-12 (item 25)	

Maintenance services indicated by a star (★) or asterisk (*) are required under the terms of the Emission Control Systems Warranty (ECSW). See Owner's Guide or Warranty Booklet for complete warranty information.

- ★ For vehicles sold in California
- * For vehicles sold outside California

- NOTE:
- (1) After 60,000 miles (96,000 km) or 72 months, inspect every 10,000 miles (16,000 km) or 12 months.
 - (2) After 60,000 miles (96,000 km) or 72 months, replace every 30,000 miles (48,000 km) or 36 months.
 - (3) After 60,000 miles (96,000 km) or 72 months, adjust every 30,000 miles (48,000 km) or 36 months.
 - (4) Replace at 60,000 miles (96,000 km) or 72 months only.
 - (5) If the propeller shaft has been immersed in water, it should be re-greased within daily.
 - (6) Applicable when operating mainly on dusty roads. If not, follow the normal condition schedule.
 - (7) Applicable when operating mainly on rough and/or muddy roads. If not, follow the normal condition schedule.
 - (8) Inspect the steering gear box for oil leakage only.

MAINTENANCE OPERATIONS

ENGINE

Cold Engine Operations

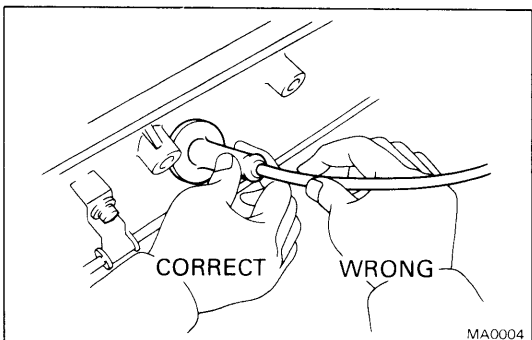
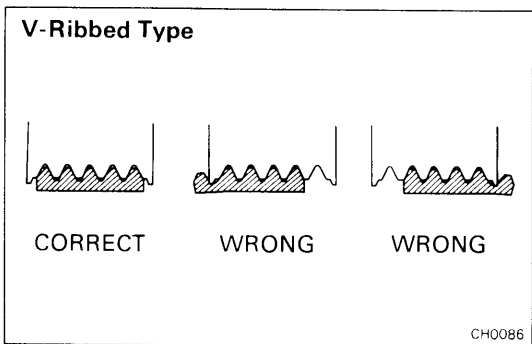
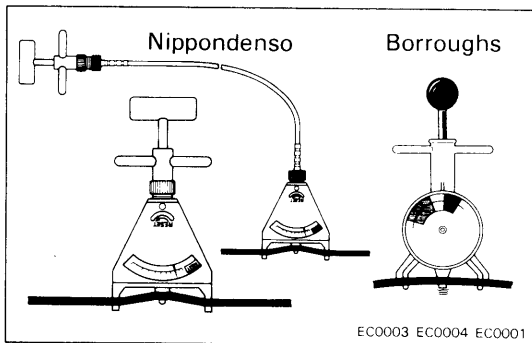
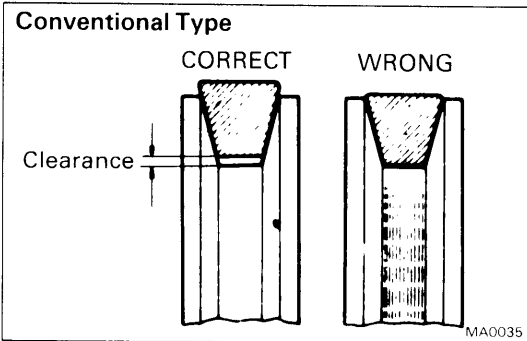
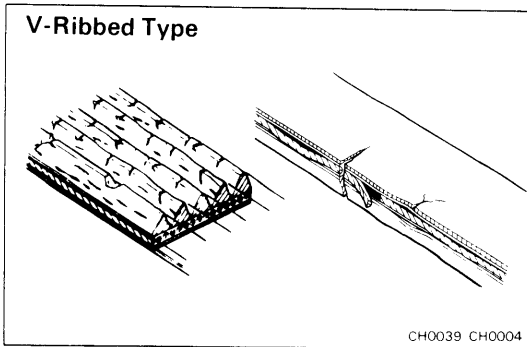

1. INSPECT V-RIBBED TYPE DRIVE BELT (ALTERNATOR) AND CONVENTIONAL TYPE DRIVE BELTS (PS PUMP AND A/C COMPRESSOR)

- (a) Visually check the belt for separation of the adhesive rubber above and below the core, core separation from the belt side, severed core, separation of the rib from the adhesive rubber, cracking or separation of the ribs, torn or worn ribs or cracks in the inner ridges of the ribs.
Conventional type only: Check that the belt does not touch the bottom of the pulley groove.

If necessary, replace the drive belt.

- (b) Using a belt tension gauge, check the drive belt tension.

Belt tension gauge:

Nippondenso BTG-20 (95506-00020) or
Borroughs No. BT-33-73F

Drive belt tension:

V-Ribbed type	Used belt	115 ± 20 lb
	New belt	175 ± 5 lb
Conventional type	Used belt	80 ± 20 lb
	New belt	125 ± 25 lb

If necessary, adjust the drive belt tension.

NOTE:

- "New belt" refers to a belt which has been used 5 minutes or less on a running engine.
- "Used belt" refers to a belt which has been used on a running engine for 5 minutes or more.
- After installing the drive belt, check that it fits properly in the ribbed grooves.
- Check by hand to confirm that the belt has not slipped out of the groove on the bottom of the pulley.
- After installing a new belt, run the engine for about 5 minutes and then recheck the belt tension.

2. REPLACE SPARK PLUGS (PLATINUM TIPPED TYPE)

- (a) Disconnect the spark plug wires at the boot. DO NOT pull on the wires.
- (b) Remove the spark plugs.

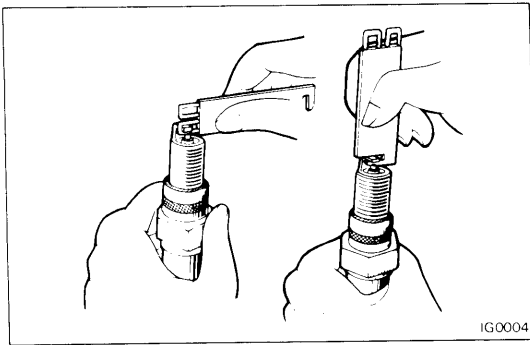

(c) Check the gap on the new plugs.

Correct electrode gap: 1.1 mm (0.043 in.)

**Recommended spark plugs: ND P16R
NGK BPR5EP11**

NOTE: If adjusting the gap of a new plug, bend only the base of the ground electrode. Do not touch the tip. Never attempt to adjust the gap on a used plug.

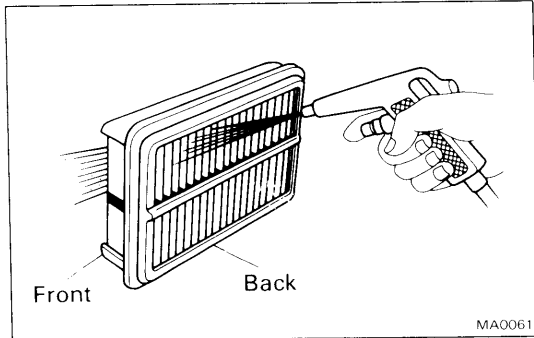

3. INSPECT AIR FILTER

- (a) Visually check that the air cleaner element is not excessively dirty, damaged or oily.
- (b) Clean the element with compressed air. First blow from the back side thoroughly. Then blow off the front side of the element.

4. REPLACE AIR FILTER

Replace the air cleaner element with a new one.

5. REPLACE ENGINE OIL AND OIL FILTER

(See page LU-4)

Engine oil grade:

API grade SF or SF/CC, multigrade viscosity and fuel-efficient oil

Drain and refill with oil filter change capacity:

3.5 liters (3.7 US qts, 3.1 Imp. qts)

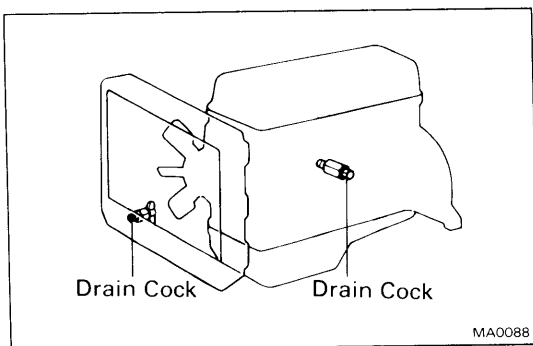

6. REPLACE ENGINE COOLANT

- (a) Drain the coolant from the radiator and engine drain cocks. (Engine drain is at left rear of engine block.)
- (b) Close the drain cocks.
- (c) Fill system with coolant.

Coolant capacity (w/ Heater):

**2WD w/o Rear heater
7.9 liters (8.3 US qts, 7.0 Imp. qts)**

**w/ Rear heater
8.4 liters (8.9 US qts, 7.4 Imp. qts)**

**4WD w/o Rear heater
7.0 liters (7.4 US qts, 6.2 Imp. qts)**

**w/ Rear heater
7.5 liters (7.9 US qts, 6.6 Imp. qts)**

Use a good brand of ethylene-glycol base coolant, mixed according to the manufacturer's instructions

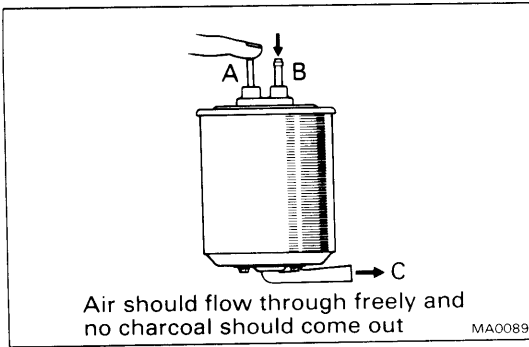

7. CALIFORNIA VEHICLES ONLY: INSPECT CHARCOAL CANISTER

- Remove the air cleaner case assembly.
- Disconnect the hoses to the charcoal canister. Label hoses for correct installation.
- Plug pipe A with your finger and blow compressed air (3 kg/cm², 43 psi or 294 kpa) through pipe B (fuel tank side).
 - Check that air comes out of the bottom pipe C without resistance.
 - Check that no activated charcoal comes out.

If necessary, replace the charcoal canister.

NOTE: Do not attempt to wash the charcoal.

- Connect the hoses to the charcoal canister.
- Reinstall the air cleaner case assembly.

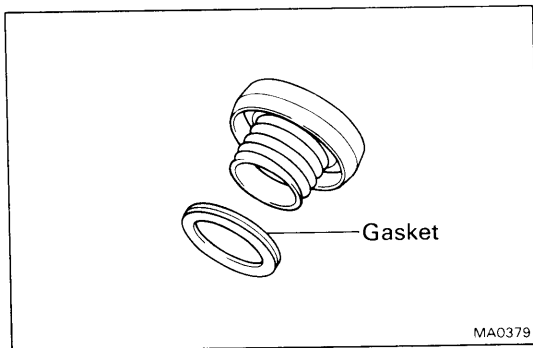

8. REPLACE GASKET IN FUEL FILLER CAP

- Remove the old gasket (O-ring) from the fuel filler cap. Do not damage the cap.
- Install the new gasket by hand.
- Inspect the cap for damage or cracks.
- Install the cap and check the torque limiter.

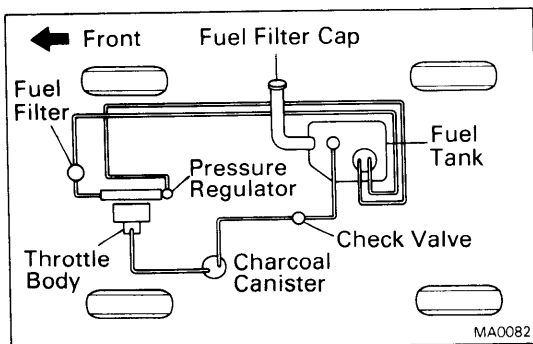

9. INSPECT FUEL LINES AND CONNECTIONS (See page FI-56)

Visually inspect the fuel lines for cracks, leakage, loose connections, deformation or tank bend looseness.

10. INSPECT EXHAUST PIPES AND MOUNTINGS

Visually inspect the pipes, hangers, and connections for severe corrosion, leaks or damage.

11. REPLACE OXYGEN SENSOR

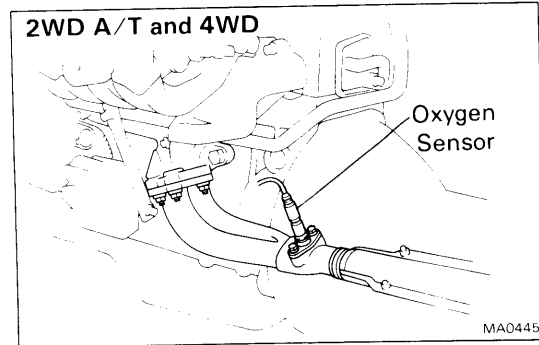
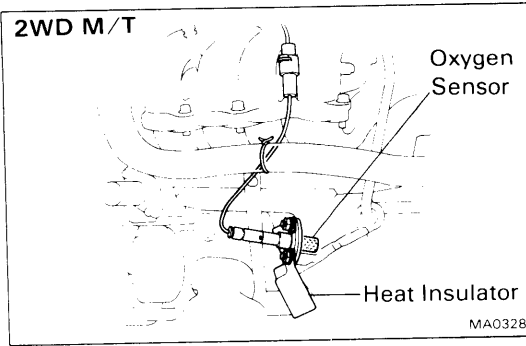

- (a) Disconnect the oxygen sensor connector.
- (b) Remove the two nuts, heat insulator (2WD M/T), oxygen sensor and gasket from the exhaust manifold (2WD M/T) or front exhaust pipe (2WD A/T and 4WD).
- (c) Install new gasket, oxygen sensor and heat insulator with the two nuts.

Torque: 200 kg-cm (14 ft-lb, 20 N·m)

- (d) Inspect the oxygen sensor operation.
(See pages FI-70 and 71)

Hot Engine Operations

12. ADJUST IDLE SPEED

- (a) Preparation
 - Air cleaner installed
 - All pipes and hoses of air intake system connected
 - All vacuum lines connected (i.e., ESA, EGR systems, etc.)
 - EFI system wiring connectors fully plugged
 - Engine at normal operating temperature
 - Accessories switches "OFF"
 - Transmission in "N" range
- (b) Disconnect the ISC VSV connector.
- (c) Connect a tachometer to the engine.
Connect the test probe of the tester to the service connector of the distributor.

CAUTION:

1. **NEVER** allow the tachometer terminal to touch ground as it could result in damage to the igniter and/or ignition coil.
2. **As some tachometers are not compatible with this ignition system, we recommend that you confirm the compatibility of your unit before using.**
- (d) Race the engine at 2,500 rpm for about 2 minutes.
- (e) Set the idle speed by turning the IDLE SPEED ADJUSTING SCREW.

**Idle speed: M/T 700 rpm
A/T 750 rpm**

- (f) Reconnect the ISC VSV connector.
- (g) Remove the tachometer.

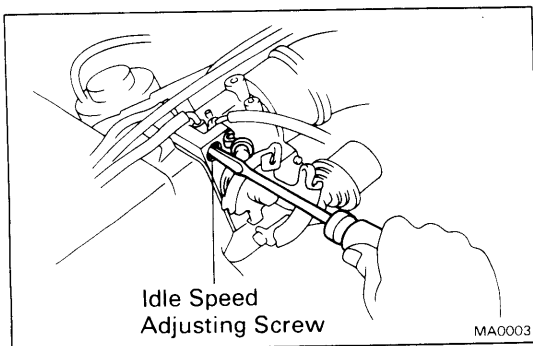
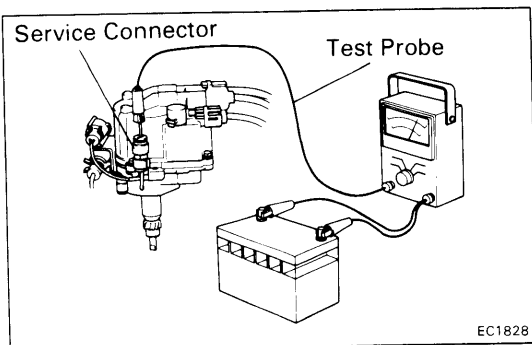
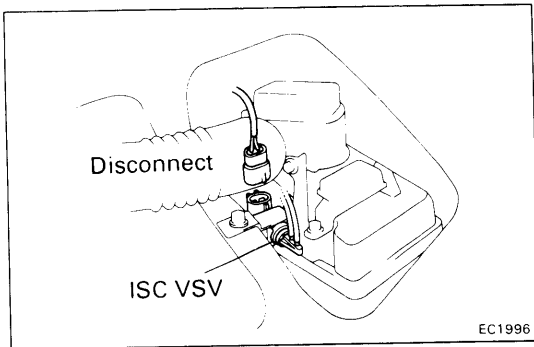

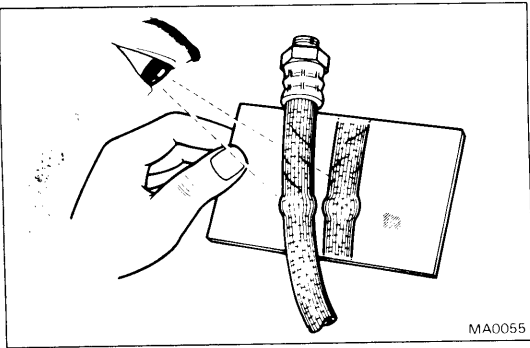

BRAKES

13. INSPECT BRAKE LINE PIPES AND HOSES

NOTE: Inspect in a well lighted area. Inspect the entire circumference and length of the brake hoses using a mirror as required. Turn the front wheels fully right or left before inspecting the front brake.

- (a) Check all brake lines and hoses for:
 - Damage
 - Wear
 - Deformation
 - Cracks
 - Corrosion
 - Leaks
 - Bends
 - Twists
- (b) Check all clamps for tightness and connections for leakage.
- (c) Check that the hoses and lines are clear of sharp edges, moving parts and the exhaust system.
- (d) Check that the lines installed in grommets, pass through the center of the grommets.

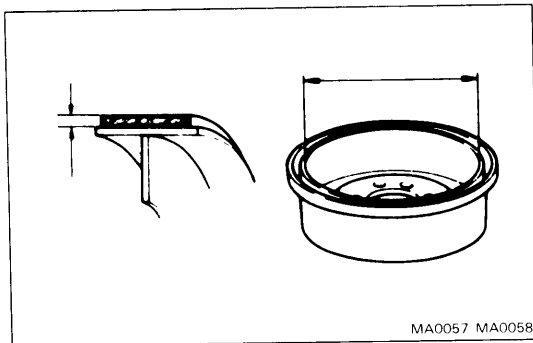

14. INSPECT REAR BRAKE LININGS AND DRUMS (See page BR-34)

- (a) Check the linings for wear.
Minimum lining thickness: 1.0 mm (0.039 in.)
- (b) Check the brake drums for scoring or wear.
Maximum drum inside diameter: 256.0 mm (10.079 in.)

(c) Clean the brake parts with a damp cloth.

NOTE: Do not use compressed air to clean brake parts.

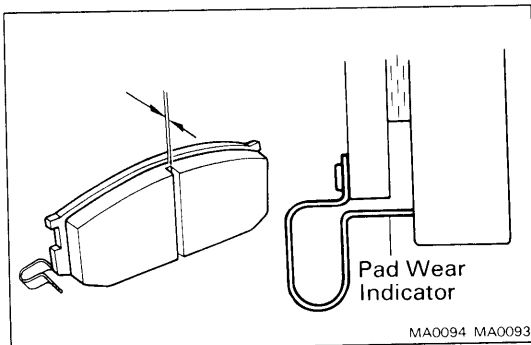

15. INSPECT FRONT BRAKE PADS AND DISCS 2WD (See page BR-21) 4WD (See page BR-28)

- (a) Check the thickness of the disc brake pads and check for irregular wear.

Minimum pad thickness: 2WD 1.0 mm (0.039 in.)
4WD 3.0 mm (0.118 in.)

NOTE: If a squealing or scraping noise occurs from the front brake during driving, check the pad wear indicator.

If there are traces of the indicator contacting the disc rotor, the disc pad should be replaced.

- (b) Check the disc for wear or runout.

Minimum disc thickness:
2WD 19.0 mm (0.748 in.)
4WD 24.0 mm (0.945 in.)

Maximum disc runout: 0.15 mm (0.0059 in.)

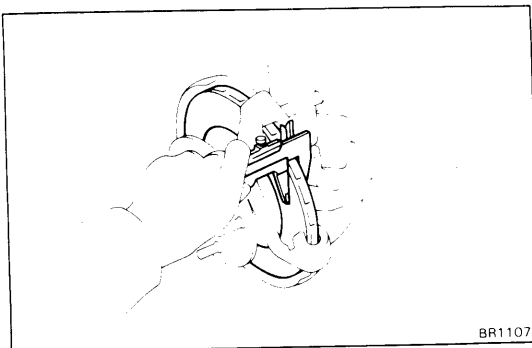

CHASSIS

16. INSPECT STEERING LINKAGE

- (a) Check the steering wheel freeplay.

Maximum steering wheel freeplay: 30 mm (1.18 in.)

With the vehicle stopped and pointed straight ahead, rock the steering wheel gently back and forth with light finger pressure.

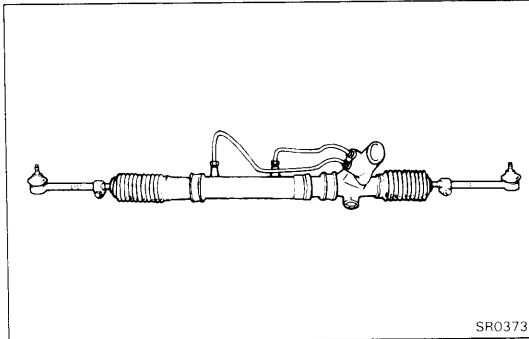
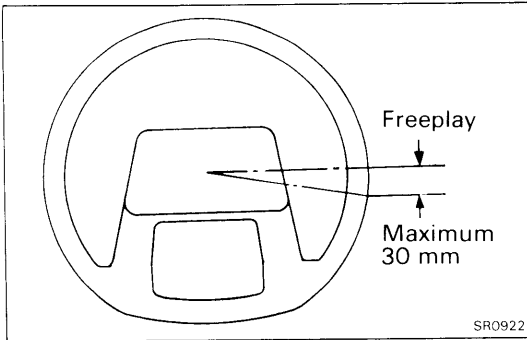

- (b) Check the steering linkage for looseness or damage.

Check that:

- Tie rod ends, relay rod ends, center arm, idler arm and drag link do not have excessive play.
- Dust seals are not damaged.

17. INSPECT STEERING GEAR BOX

Check the steering gear box for oil leakage.

18. (4WD) INSPECT DRIVE SHAFT BOOT

Check the drive shaft boots for clamp looseness, grease leakage or damage.

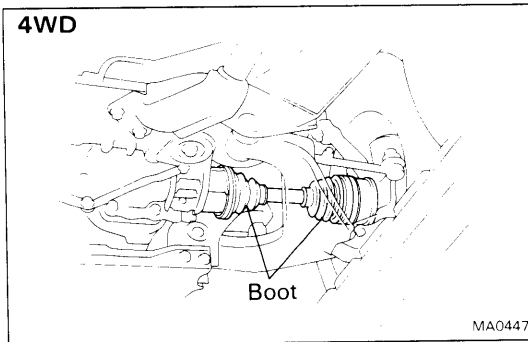

19. INSPECT BALL JOINTS AND DUST COVERS

- (a) Check the upper and lower ball joints for excessive looseness.

2WD (See pages FA-16)

4WD (See pages FA-99)

Maximum ball joint vertical play:

Lower 0 mm (0 in.)

Upper 2.3 mm (0.091 in.)

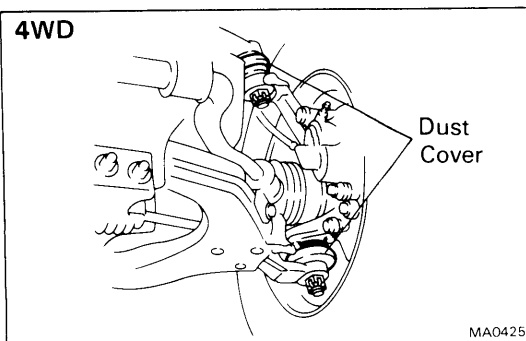
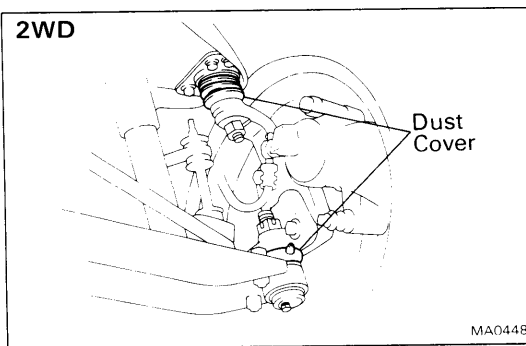

20. REPACK FRONT WHEEL BEARINGS AND THRUST BUSH (4WD)

(a) Change the front wheel bearing grease.

2WD (See page FA-9 to 12)

4WD (See page FA-53 to 56)

Grease grade: Lithium base multipurpose grease (NLGI No.2)

Wheel bearing friction preload:

2WD at rotating 350 — 870 g

(0.8 — 1.9 lb, 3.4 — 8.5 N)

4WD at starting 1.0 — 2.4 kg

(2.2 — 5.3 lb, 10 — 24 N)

(b) Repack the drive shaft thrust bush grease.
(See page FA-57 to 61)

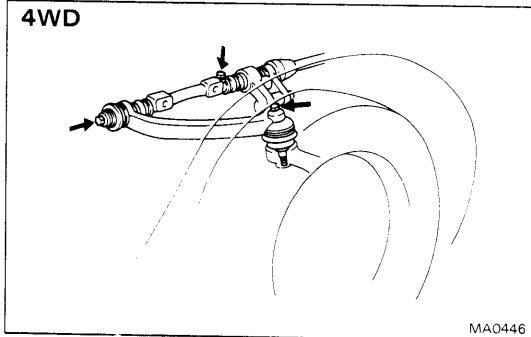

21. (4WD)

LUBE STEERING KNUCKLE AND CHASSIS GREASE (Including Propeller shaft)

(a) (Upper suspension arm)

- Remove the three screw plugs.
- Repack the suspension arm with grease.

Grease grade: Molybdenum disulphide lithium base grease (NLGI No.2)

- Reinstall the three screw plugs.

(b) (Propeller shaft)

Repack the sleeve yoke with grease.

Grease grade: Lithium base multipurpose grease (NLGI No.2)

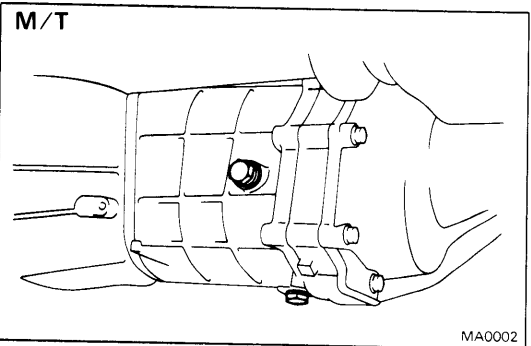
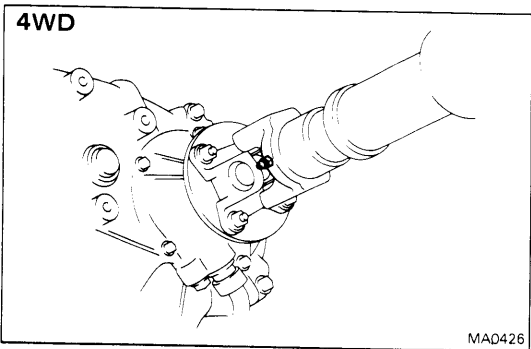

22. CHECK TRANSMISSION (A/T OR M/T), TRANSFER AND DIFFERENTIAL OIL

(a) Visually check the transmission, transfer and differential for oil leakage.

If leakage is found, check for cause and repair.

(b) (A/T)

Check the oil level and refill if necessary.

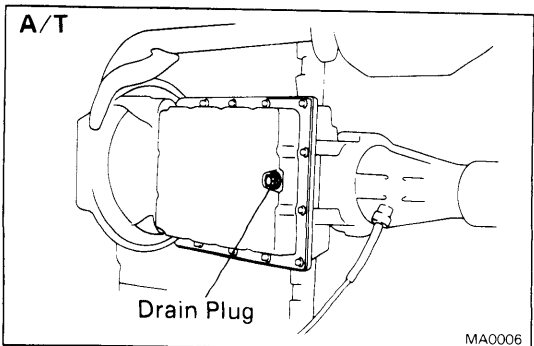

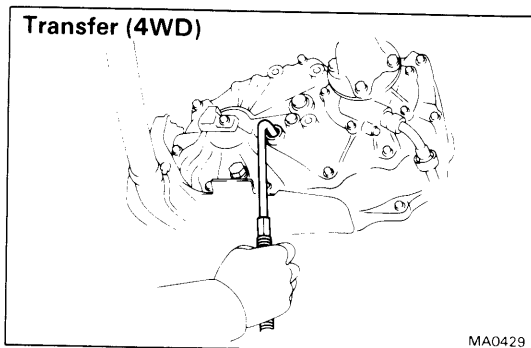
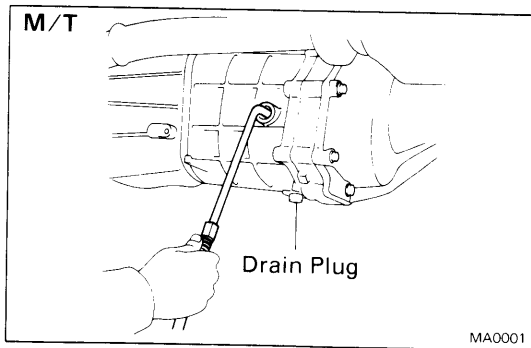
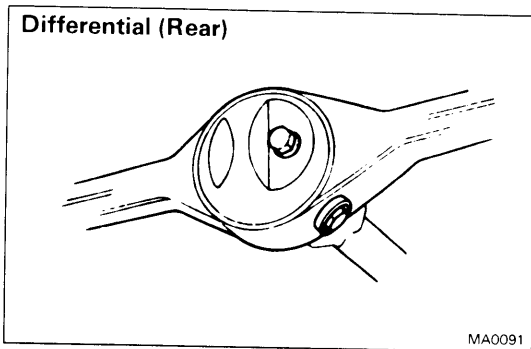
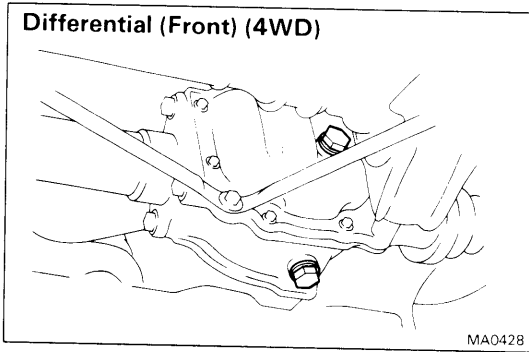
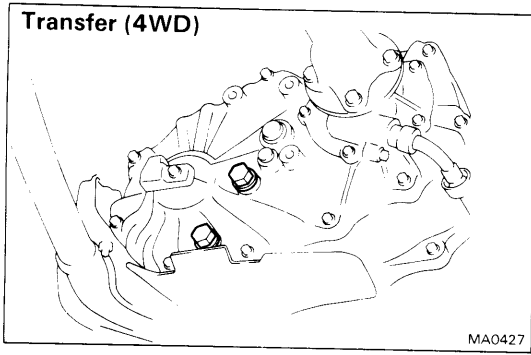

23. REPLACE MANUAL TRANSMISSION, TRANSFER AND DIFFERENTIAL OIL

- (a) Remove the filler plug.
- (b) Remove the drain plug, and drain the oil.
- (c) Reinstall a new gasket and the drain plug.
- (d) Add new oil until it begins to run out of the filler hole.

Transmission oil—

Oil grade: API GL-4 or GL-5

Viscosity: SAE 75W-90

Capacity:

2WD 2.2 liters (2.3 US qts, 1.9 Imp. qts)

4WD 2.6 liters (2.7 US qts, 2.3 Imp. qts)

Transfer (4WD)—

Oil grade: API GL-4 or GL-5

Viscosity: SAE 75W-90

Capacity: 1.2 liters (1.3 US qts, 1.1 Imp. qts)

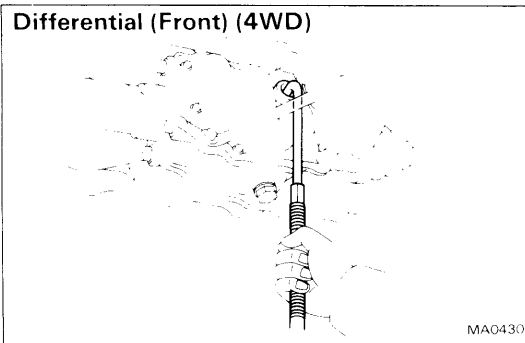

Differential oil—

Oil grade: Hypoid gear oil API GL-5
Viscosity: Above -18°C (0°F) SAE 90
 Below -18°C (0°F) SAE 80W-90 or 80W

Capacity:
 2WD 1.45 liters (1.5 US qts, 1.3 Imp. qts)
 4WD Front 1.2 liters (1.3 US qts, 1.1 Imp. qts)
 Rear 1.85 liters (2.0 US qts, 1.6 Imp. qts)

(e) Install a new gasket and the filler plug.

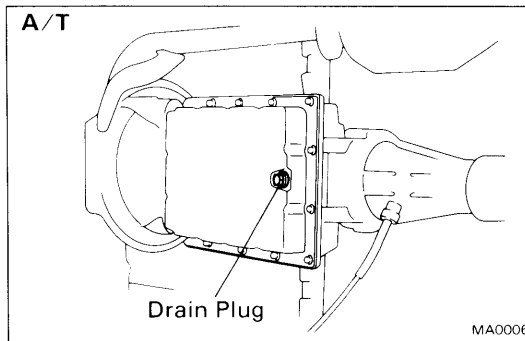
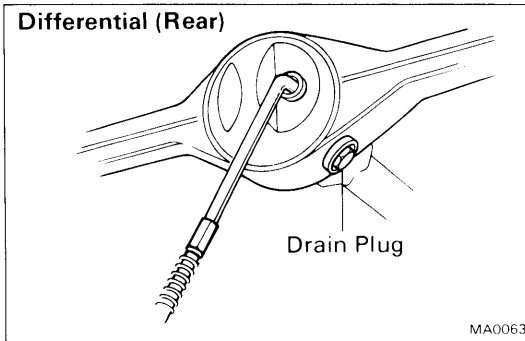

24. REPLACE AUTOMATIC TRANSMISSION FLUID

- (a) Remove the drain plug, and drain the fluid.
- (b) Securely reinstall the drain plug.
- (c) With the engine OFF, and new fluid through the dipstick tube.

Drain and refill capacity:

2.5 liters (2.6 US qts, 2.2 Imp. qts)

- (d) Start the engine and shift the selector into all positions from P through L, and then shift into P.
- (e) With the engine idling, check the fluid level. Add fluid up to the COOL level on the dipstick.

CAUTION: Do not overfill.

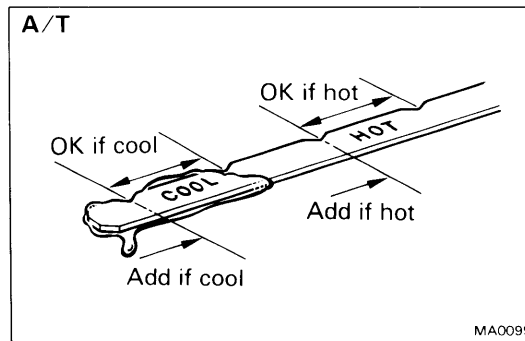

25. TIGHTEN BOLTS AND NUTS ON CHASSIS AND BODY

Tighten the following parts:

- Front seat mount bolts

Torque: 375 kg-cm (27 ft-lb, 37 N·m)

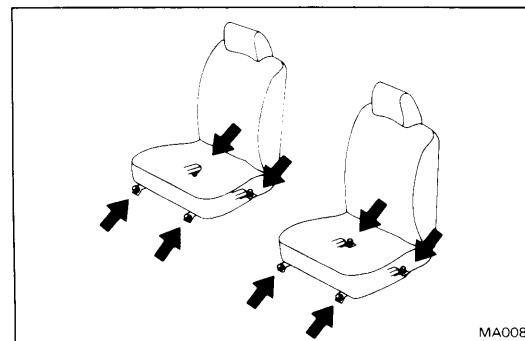

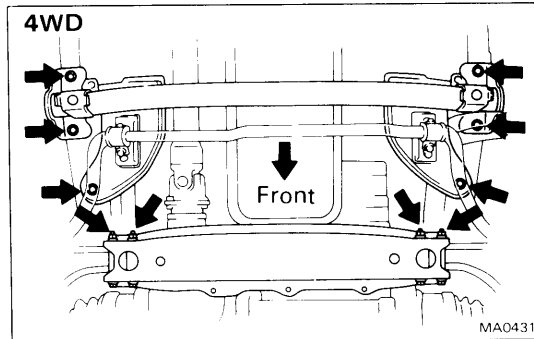
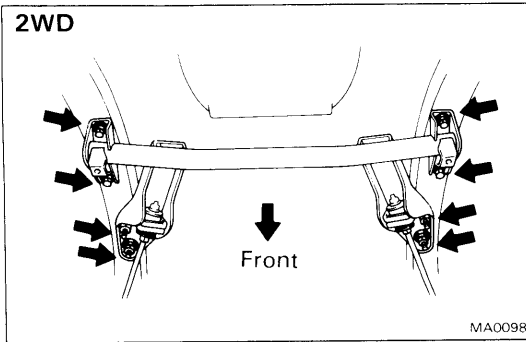

- Engine front mounting member-to-body mount bolts

Torque: 400 kg-cm (29 ft-lb, 39 N·m)

- (2WD) Strut bar bracket-to-body mount bolts

Torque: 900 kg-cm (65 ft-lb, 88 N·m)

- Stabilizer bar bracket-to-body mount bolt

Torque: 900 kg-cm (65 ft-lb, 88 N·m)

- (4WD) Front suspension rear crossmember-to-body mount bolts

Torque: 970 kg-cm (70 ft-lb, 95 N·m)

26. FINAL INSPECTION

- Check the operation of the body parts:
 - Front and rear doors
 - Door locks operate properly
 - Doors close properly
 - Back door
 - Door lock operates properly
 - Seats
 - Seats adjust easily and lock securely in any position
 - Front seat back locks securely in any position
 - Fold-down rear seat backs lock securely
- Road test
 - Check the engine and chassis for abnormal noise.
 - Check that the vehicle does not wander or pull to one side.
 - Check that the brakes work properly and do not drag.
- Be sure to deliver a clean car and especially check:
 - Steering wheel
 - Shift lever knob
 - All switch knobs
 - Door handles
 - Seats

GENERAL MAINTENANCE

These are the maintenance and inspection items which are considered to be the owner's responsibility. They can be performed by the owner or he can have them done at a service shop. These items include those which should be checked on a daily basis, those which, in most cases, do not require (special) tools and those which are considered to be reasonable for the owner to perform.

Items and procedures for general maintenance are as follows.

OUTSIDE VEHICLE

1. TIRES

- (a) Check the pressure with a gauge. Adjust if necessary.
- (b) Check for cuts, damage or excessive wear.

2. WHEEL NUTS

When checking the tires, check the nuts for looseness or for missing nuts. If necessary, tighten them.

3. TIRE ROTATION

It is recommended that tires be rotated every 7,500 miles (12,000 km).

4. WINDSHIELD WIPER BLADES

Check for wear or cracks whenever they do not wipe clean. Replace if necessary.

5. FLUID LEAKS

- (a) Check underneath for leaking fuel, oil, water or other fluid.
- (b) If you smell gasoline fumes or notice any leak, have the cause found and corrected.

6. DOORS

Check that all doors including the slide and back door operate smoothly, and that all latches lock securely.

INSIDE VEHICLE

7. LIGHTS

- (a) Check that the headlights, stop lights, taillights, turn signal lights, and other lights are all working.
- (b) Check the headlight aiming.

8. WARNING LIGHTS AND BUZZERS

Check that all warning lights and buzzers function properly.

9. HORN

Check that it is working.

10. WINDSHIELD GLASS

Check for scratches, pits or abrasions.

11. WINDSHIELD WIPER AND WASHER

- (a) Check operation of the wipers and washer.
- (b) Check that the wipers do not streak.

12. WINDSHIELD DEFROSTER

Check that air comes out from the defroster outlet when operating the heater or air conditioner.

13. REAR VIEW MIRROR

Check that it is mounted securely.

14. SUN VISORS

Check that they move freely and are mounted securely.

15. STEERING WHEEL

Check that it has specified freeplay. Be alert for changes in steering condition, such as hard steering, excessive freeplay or strange noise.

16. SEATS

- (a) Check that all front seat controls such as seat adjusters, seatback recliner, etc. operate smoothly.
- (b) Check that all latches lock securely in any position.
- (c) Check that the locks hold securely in any latched position.
- (d) Check that the head restraints move up and down smoothly and that the locks hold securely in any latched position.
- (e) For folding-down rear seat backs, check that the latches lock securely.

17. SEAT BELTS

- (a) Check that the seat belt system such as buckles, retractors and anchors operate properly and smoothly.
- (b) Check that the belt webbing is not cut, frayed, worn or damaged.

18. ACCELERATOR PEDAL

Check the pedal for smooth operation and uneven pedal effort or catching.

19. CLUTCH PEDAL (See page CL-3)

Check the pedal for smooth operation.
Check that the pedal has the proper freeplay.

20. BRAKE PEDAL (See page BR-5)

- (a) Check the pedal for smooth operation.
- (b) Check that the pedal has the proper reserve distance and freeplay.
- (c) Check the brake booster function.

21. BRAKES

At a safe place, check that the brakes do not pull to one side when applied.

22. PARKING BRAKE (See page BR-7)

- (a) Check that the lever has the proper travel.
- (b) On a safe incline, check that vehicle is held securely with only the parking brake applied.

23. AUTOMATIC TRANSMISSION "PARK" MECHANISM

- (a) Check the lock release button of the selector lever for proper and smooth operation.
- (b) On a safe incline, check that vehicle is held securely with the selector lever in the "P" position and all brakes released.

24. WINDSHIELD WASHER FLUID

Check that there is sufficient fluid in the tank.

25. ENGINE COOLANT LEVEL

Check that the coolant level is between the "FULL" and "LOW" lines on the see-through reservoir.

26. RADIATOR AND HOSES

- (a) Check that the front of the radiator is clean and not blocked with leaves, dirt or bugs.
- (b) Check the hoses for cracks, kinks, rot or loose connections.

27. BATTERY ELECTROLYTE LEVEL

Check that the electrolyte level of all battery cells is between the upper and lower level

lines on the case. If level is low, add distilled water only.

28. BRAKE AND CLUTCH FLUID LEVELS

Check that the brake fluid level is within 10 mm (0.39 in.) below the "MAX" line on the see-through reservoir.

29. ENGINE DRIVE BELTS

Check all drive belts for fraying, cracks, wear or oiliness.

30. ENGINE OIL LEVEL

Check the level on the dipstick with the engine turned off.

31. POWER STEERING FLUID LEVEL

Check the level on the dipstick.
The level should be in the "HOT" or "COLD" range depending on the fluid temperature.

32. AUTOMATIC TRANSMISSION FLUID LEVEL

- (a) Park the vehicle on a level surface.
- (b) With the engine idling and the parking brake applied, shift the selector into all positions from "P" to "L", and then shift into "P".
- (c) Pull out the dipstick and wipe off the fluid with a clean rag. Reinsert the dipstick and check that the fluid level is in the HOT range.
- (d) Perform this check with the fluid at normal driving temperature (70 - 80°C or 158 - 176°F).

NOTE: Wait about 30 minutes before checking the fluid level after extended driving at high speeds, in hot weather, in heavy traffic or with a trailer.

33. EXHAUST SYSTEM

Visually inspect for cracks, holes or loose supports.

If any change in the sound of the exhaust or smell of the exhaust fumes is noticed, have the cause located and corrected.